

# FemtoFiber<sup>®</sup> pro

## Ultrafast Erbium Fiber Laser System

### Manual

Manual: M-043 Version 06  
Copyright © 2015 TOPTICA Photonics AG

TOPTICA Photonics AG  
Lochhamer Schlag 19  
D-82166 Graefelfing/Munich  
Tel.: +49 89 85837-0  
Fax: +49 89 85837-200

email: [info@toptica.com](mailto:info@toptica.com)  
<http://www.toptica.com>

**(June 2015 Subject to change without notice)**



**Dear Customer,**

Welcome to the TOPTICA community!

We have designed this product to be easy to use and reliable so that you can focus on your work. If you have questions or need advice on how to integrate it into your setup, please contact us immediately so we can walk you through the process. We will provide you with quick and competent help through our service staff and product managers.

You can contact us in the following ways:

- Internet: [service.toptica.com](http://service.toptica.com). In our support section you can find a list of frequently asked questions and a service contact form
- Email: [service@toptica.com](mailto:service@toptica.com)
- Phone: +49-89-85837-150.

Our customers in the USA and Canada may contact TOPTICA Photonics Inc.:

- Phone: +1-585-657-6663

Please have your product -ID and serial number ready when contacting us so we can quickly retrieve all relevant information.

As we are constantly improving our products, we greatly value all customer feedback. We encourage you to tell us what you like about our products as well as any suggestions for improvement.

Best regards,

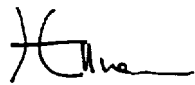

Harald Ellmann  
Service Manager  
TOPTICA Photonics AG



# Contents

<b>1</b>	<b>The FemtoFiber® pro Laser System</b>	<b>5</b>
1.1	Principle of Operation	6
1.2	System Variants	7
1.2.1	Infrared System FemtoFiber® pro IR	7
1.2.2	Infrared System FemtoFiber® pro IRS	8
1.2.3	Near-Infrared System FemtoFiber® pro NIR	9
1.2.4	Super Continuum Infrared System FemtoFiber® pro SCIR	11
1.2.5	Ultra Compressed Pulse System FemtoFiber® pro UCP	12
1.2.6	Tunable Visible System FemtoFiber® pro TVIS	13
1.2.7	Tunable Near Infrared System FemtoFiber® pro TNIR	15
1.3	Options	18
1.3.1	Multi-Arm Laser System (Suffix AMP)	18
1.3.2	Third/Fourth Arm for Seeding Extensions	18
1.3.3	Oscillator Repetition Rate 40 MHz or Customized (Suffix M40 or MCUST)	19
1.3.4	Variable Laser Repetition Rate (Suffix VAR)	19
1.3.5	Laser Repetition Rate Control (Suffix LRC)	20
1.3.6	TNIR Secondary Output for UCP and TVIS (Suffix TNIR)	21
<b>2</b>	<b>Safety Instructions and Warnings</b>	<b>22</b>
2.1	General Safety Terms	22
2.2	Safety Labels	24
2.2.1	Protective Housing	24
2.2.2	Laser Beam	24
2.2.3	Apertures	25
2.2.4	CFR Compliance	25
2.3	Identification of Manufacturer	26
2.3.1	FemtoFiber® pro Control Unit	26
2.3.2	FemtoFiber® pro Laser Head	26
2.4	Identification Labels	26
2.5	Safety Features of the FemtoFiber® pro Laser System	27
2.5.1	External Interlock	27
2.5.2	Laser Beam Shutter	28
2.5.3	Fuses	29
<b>3</b>	<b>Installation</b>	<b>30</b>
3.1	Inspection after Delivery	30
3.2	Installation Instructions FemtoFiber® pro Laser Head	33
<b>4</b>	<b>Operation</b>	<b>34</b>
4.1	Operator Controls FemtoFiber® pro Laser Head	34
4.1.1	Description of Operator Controls FemtoFiber® pro Laser Head	35
4.2	Operator Controls FemtoFiber® pro Control Unit	36
4.2.1	Description of Operator Controls FemtoFiber® pro Control Unit	37
4.3	Connection of the FemtoFiber® pro Laser System	38
4.3.1	FemtoFiber® pro Multi-Arm Laser Systems	38
4.3.2	Additional Connections FemtoFiber® pro with VAR and LRC Option	39
4.4	Power Up of FemtoFiber® pro Systems	40
4.5	Power Down	40

<b>5</b>	<b>Computer Control of the FemtoFiber® pro Laser System</b>	<b>41</b>
5.1	USB Connection	41
5.1.1	Installation of FTDI CDM Drivers for USB Connection	41
5.2	Installation of FemtoFiber® pro GUI-Software	44
5.3	Start of FemtoFiber® pro GUI-Software	48
5.4	Operation of FemtoFiber® pro GUI-Software	49
5.4.1	General	49
5.4.2	Connection Tab	50
5.4.3	Laser Control Tab	51
5.4.4	Laser Control Tab Standard System UCP and TVIS Variant	52
5.4.5	Laser Control Tab Multi-Arm Laser System	53
5.4.6	Info Tab	54
5.4.7	Console Tab	55
5.5	Ethernet Connection	56
5.5.1	Installation of the Ethernet Connection	56
5.6	Web Frontend	57
5.6.1	Operation	58
5.6.2	Python Command List	58
5.6.3	Console	59
5.6.4	System Properties	60
5.6.5	Debug Logfile	60
5.6.6	Service Logfile	60
5.6.7	Data Transfer	60
5.6.8	Firmware Update	61
<b>6</b>	<b>Appendix</b>	<b>62</b>
6.1	Specifications of FemtoFiber® pro Laser Systems	62
6.2	FemtoFiber® pro with VAR Option	62
6.2.1	Installation	62
6.2.2	Additional Connections	62
6.3	FemtoFiber® pro with LRC Option	63
6.3.1	Installation	63
6.3.2	Additional Connections	63
6.3.3	LRC Plug in Modules	64
6.3.4	LRC Software and Drivers	68
6.3.5	Quick Start	72
6.3.6	Switch-Off Procedure	72
6.3.7	Software and Driver Installation with Windows 7	73
6.4	Computer Control via RS 232 Connection	75
6.5	Firmware Update	76
6.6	Troubleshooting	78
6.6.1	Selftest, System Status and Error Logging	78
6.7	General Information on the Python Programming Language	79
6.7.1	Properties	79
6.7.2	Commands	80
6.7.3	Error Messages	81
6.8	Userlevels	82
6.8.1	General	82
6.8.2	Changing the UserLevel	82

---

6.9	FemtoFiber® pro Operation via Software Commands	83
6.9.1	Basic Operation	83
6.9.2	Tuning the internal Pulse Compressor	83
6.9.3	Tuning the internal SF 10 Compressor (only UCP and TVIS)	85
6.9.4	Reducing the Power Level	86
6.9.5	System Status	86
6.9.6	Troubleshooting	87
6.9.7	Error Log	88
6.9.8	Full Command Set	89
6.10	Declaration of CE Conformity	90
6.11	FemtoFiber® pro Laser Head Main Dimensions (IR/IRS/NIR/SCIR)	91
6.12	FemtoFiber® pro Laser Head Main Dimensions (UCP/TNIR/TVIS)	92
6.13	FemtoFiber® pro Laser Head Mounting Options (IR/IRS/NIR/SCIR)	93
6.14	FemtoFiber® pro Laser Head Mounting Options (UCP/TVIS/TNIR)	94
6.15	EU Legislation for Electrical and Electronic Equipment (EEE)	95
<b>7</b>	<b>Guarantee and Service</b>	<b>96</b>





## 1 The FemtoFiber® pro Laser System

Mode-locked femtosecond lasers have nowadays found their way into a wide variety of both scientific and industrial applications. With the FemtoFiber® pro Laser System, TOPTICA Photonics AG merges the performance of traditional Ti:Sapphire oscillators with the advantages of an all-fiber laser source. Combining pump sources, a SAM (saturable absorber mirror) mode-locked ring oscillator, an all-fiber core-pumped amplifier and optical pulse compression into a single compact housing, the FemtoFiber® pro Laser System offers a maximum of user-convenience and flexibility without compromising performance.

Ultrafast spectroscopy with femtosecond laser pulses continues to be a flourishing field of scientific interest. To date, a multitude of experiments has been carried out with free-space Ti:Sapphire sources. Although these systems offer high output power and good pulse characteristics, their operation is often cumbersome for the user. Mode-locking is typically accomplished via nonlinear self-focussing, requiring highly precise alignment and daily readjustment of the laser cavity. Moreover, the need for a high-power pump source in the green spectral range has led to considerable system costs and increased space requirements.

The release of TOPTICA's mode-locked Er: fiber laser system FemtoFiber® pro marked a significant step forward towards the availability of cutting-edge femtosecond technology as a standard tool in any research environment. Based on direct pumping from fiber-pigtailed laser diodes and fiber integrated, reliable telecom components, the FemtoFiber® pro Laser System delivers more than 350 mW of linearly polarized and highly stable output power in sub-100 fs pulses in a user-friendly and compact design. Due to its superior performance, high stability, great flexibility, excellent cost-efficiency and advanced user-friendliness, the new FemtoFiber® pro Laser System can be the ideal solution to your research in fields as diverse as ultrafast spectroscopy, optical frequency metrology, THz spectroscopy, confocal microscopy, material sciences and many more.



**Figure 1** The FemtoFiber® pro laser system

## 1.1 Principle of Operation

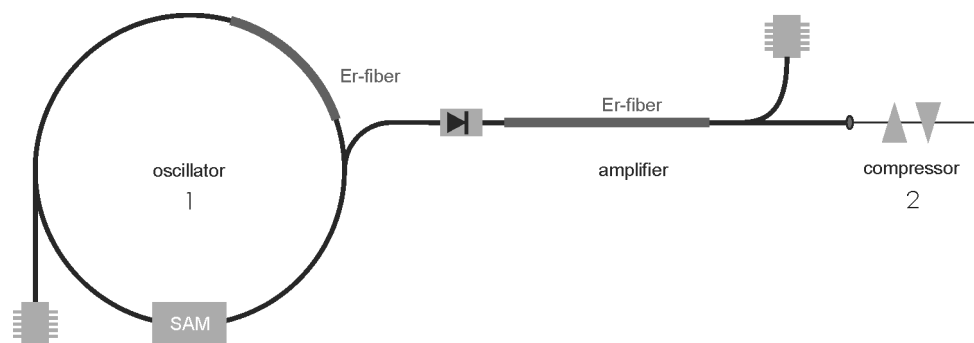

**Figure 2** Schematic setup of the FemtoFiber® pro laser system

The FemtoFiber® pro Laser System illustrated in Figure 2 is based on state-of-the-art telecom components. A core-pumped fiber, doped with Erbium ions, acts as the active laser medium. A so called saturable absorber mirror (SAM) inside the ring cavity (1) in Figure 2 favors mode-locked operation over continuous wave laser activity by exploiting the effect of picking and amplifying only pulses with a certain amplitude. As a consequence, the mode locked ring oscillator generates well-defined light pulses at a center wavelength of 1560 nm with a repetition rate of 80 MHz (standard, other rep. rates upon request).

With the high gain available from Er:fibers, the optical power extracted from the oscillator is used for seeding optical amplifiers. Every laser system contains an internal amplifier, but also has one (or more) FC/APC ports for seeding external amplifiers, e.g. for multiple beam experiments needing synchronized pulses, such as pump-probe experiments.

The pulse duration is controlled by a variable dispersion control unit, formed by a motorized prism compressor (2). The light pulses typically exhibit a duration of less than 100 fs (or longer if desired) with an average power of more than 350 mW.

## 1.2 System Variants

### 1.2.1 Infrared System FemtoFiber® pro IR

The basic system of the FemtoFiber® pro series, the FemtoFiber® pro IR, is a compact system comprising oscillator, amplifier and prism compressor in a single box. The unit delivers a collimated free-beam with more than 350 mW at 1560 nm fundamental wavelength.

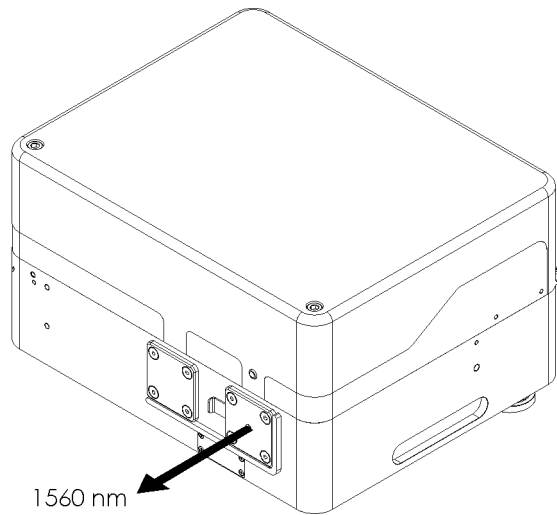

**Figure 3** FemtoFiber® pro IR laser beam

The basic properties of a FemtoFiber® pro IR are shown in the following typical measurements.

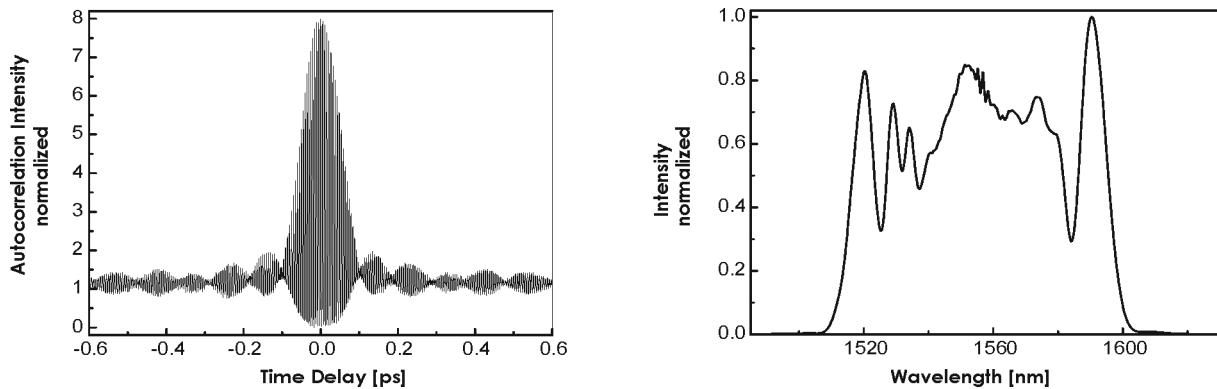
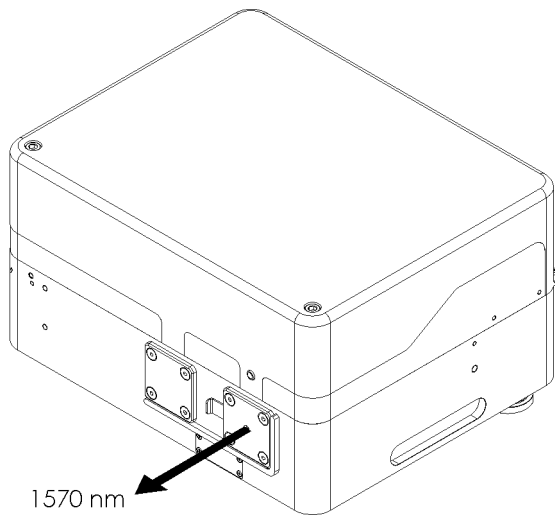

**Figure 4** Typical pulse characteristics and emission spectrum of FemtoFiber® pro IR

The pulses show a width of less than 100 fs using the auto correlation measurement method (Figure 4 left). The laser also shows a typ. 80 nm wide spectrum centered at the fundamental wavelength 1560 nm (Figure 4 right).

## 1.2.2 Infrared System FemtoFiber® pro IRS

The FemtoFiber® pro IRS is the short-pulse version of TOPTICA's FemtoFiber® pro IR. It comprises a very robust master-oscillator with power amplifier in one single box. With a prism compressor and a special non-linear fiber, shortest pulses at the fundamental wavelength of Er-doped fiber lasers are generated. The system allows to optimize the pulse characteristics manually to individual needs, alternatively the pulse length can be controlled by an automated feedback-loop.



**Figure 5** FemtoFiber® pro IRS laser beam

The basic properties of a FemtoFiber® pro IRS are shown in the following typical measurements.

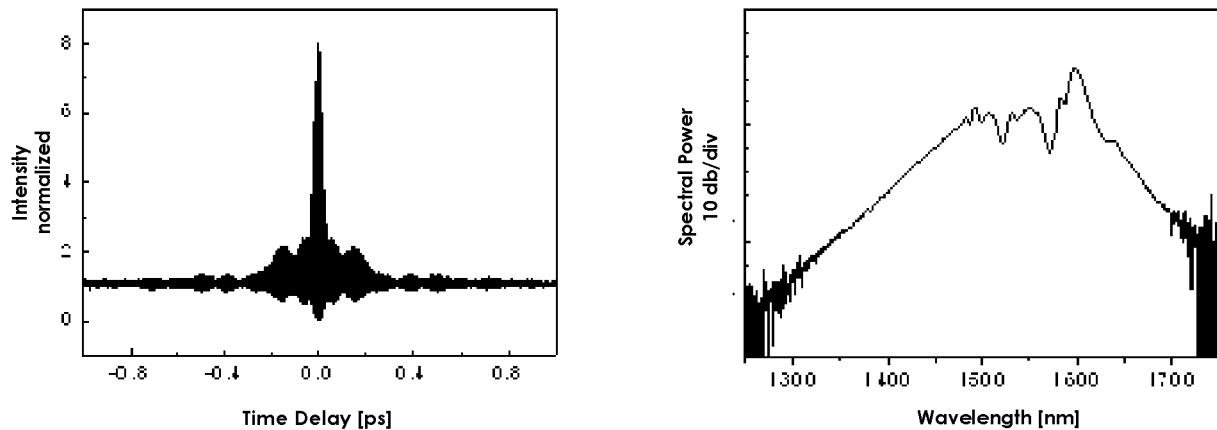

**Figure 6** Typical Pulse characteristics and emission spectrum of FemtoFiber® pro IRS

### 1.2.3 Near-Infrared System FemtoFiber® pro NIR

In addition to the features of the FemtoFiber® pro IR, the FemtoFiber® pro NIR includes an additional exit aperture with a single-pass second-harmonic generation (SHG) using a periodically poled Li:NbO<sub>3</sub> (PPLN) crystal. The FemtoFiber® pro NIR therefore provides two switchable exit ports for the fundamental wavelength 1560 nm (> 350 mW) and the second harmonic of 780 nm (> 140 mW).

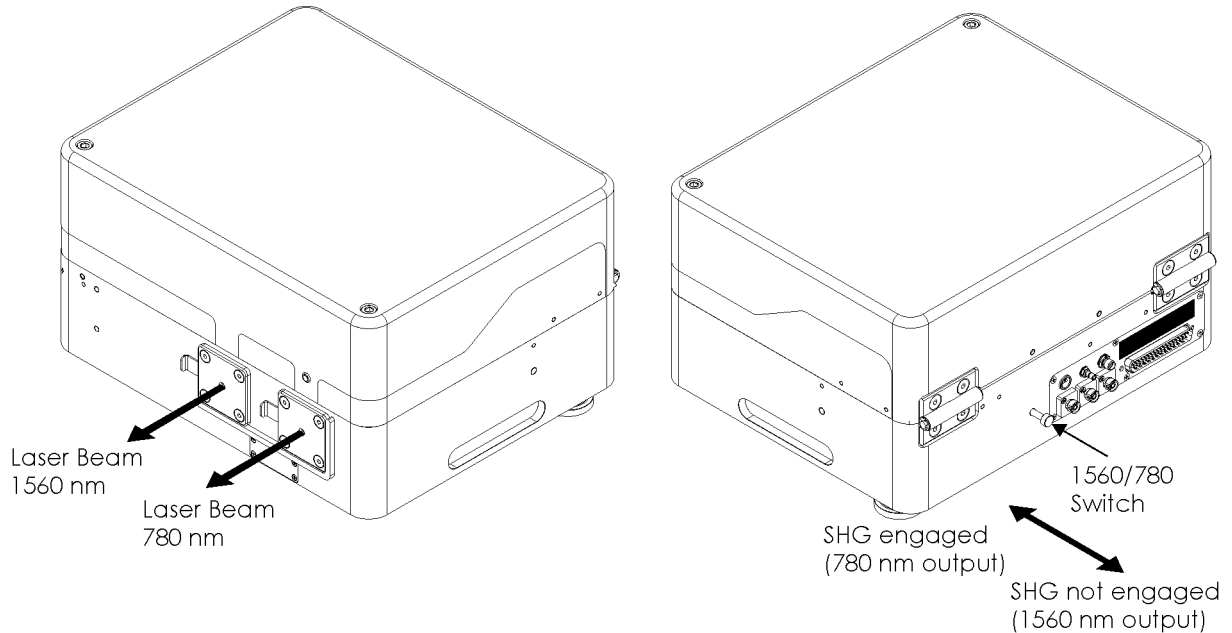

**Figure 7** FemtoFiber® pro NIR laser beams and operation of 1560/780-switch (right)

**NOTE !** Switching between 780 and 1560 nm is done by a mechanical switch, which is inserting or removing a mirror (see Figure 8) into/from the beam path and either reflects the fundamental 1560 nm to the secondary aperture or passes it towards the SHG unit and to the primary aperture. Both wavelengths simultaneously are not available (with standard/default configuration)..  
**For laser safety reasons switch OFF the laser emission or make sure the shutters are closed before operating the 1560/780-Switch !**

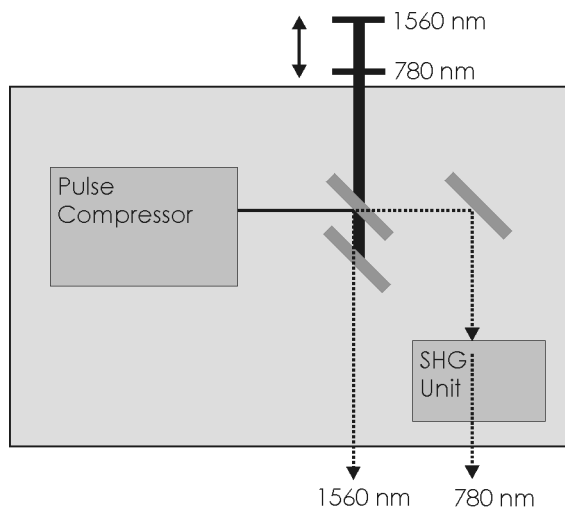

**Figure 8** FemtoFiber® pro NIR internal setup

The typical characteristics of the fundamental wavelength are the same as shown for the basic system FemtoFiber® pro IR (see Figure 4). The frequency-doubled characteristics are shown in the following typical measurements.

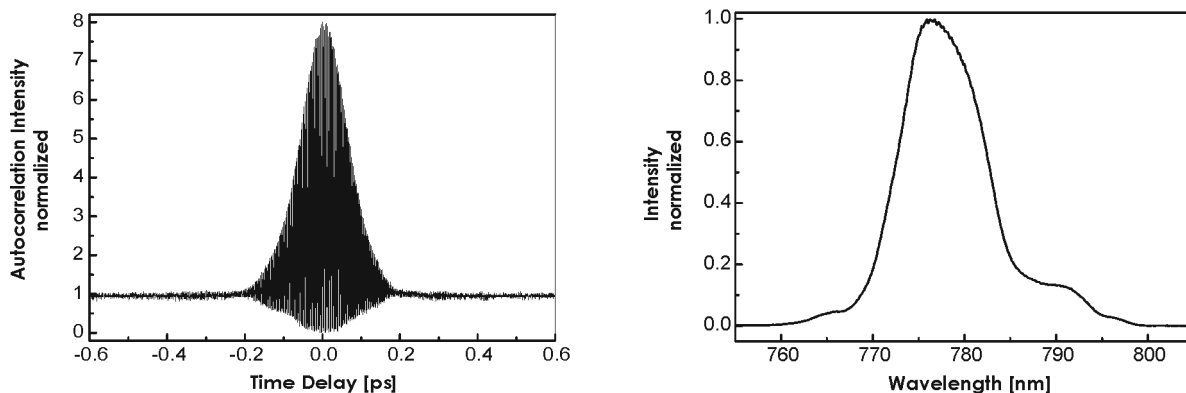

**Figure 9** Typical pulse characteristics and emission spectrum of FemtoFiber® pro NIR (SHG output)

The auto correlation shows a smooth shape with a pulse width of less than 100 fs, similar to the measurement at the fundamental wavelength (Figure 9 left). The spectral width is typically 10 - 15 nm wide (Figure 9 right).

The FemtoFiber® pro NIR variant is equipped with an auto optimize feature which constantly adjusts the average power to maximum when active. For details of the operation please refer to section 5.4.3.

### 1.2.3.1 1 ps Option for FemtoFiber® pro NIR

This option uses a different crystal and generates typ. 1 ps long, rectangular shaped pulses. The pulses are nearly transform-limited (spectral width in few nm range). The output power of such a system typically reaches 100 mW.

**NOTE !** The 1 ps option replaces the regular SHG crystal, which is not available anymore when this option is added.

### 1.2.4 Super Continuum Infrared System FemtoFiber® pro SCIR

Alternately to the second-harmonic stage, the FemtoFiber® pro SCIR provides a supercontinuum generation by using a highly nonlinear fiber (HLNF). This fiber generates a widened spectrum of 980 to 2200 nm, which is available at the primary exit aperture.

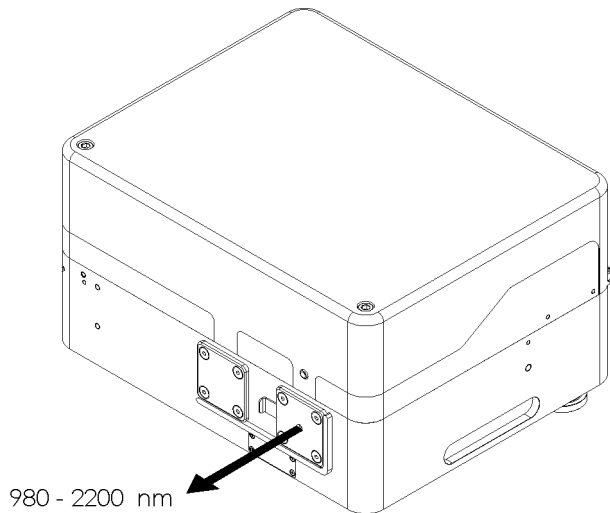

**Figure 10** FemtoFiber® pro SCIR laser beam

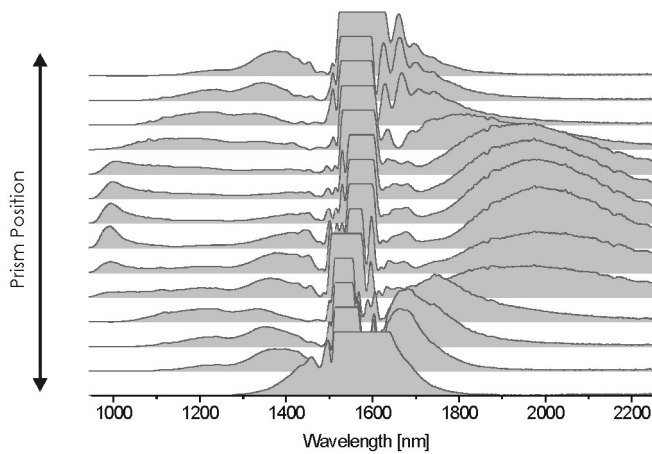
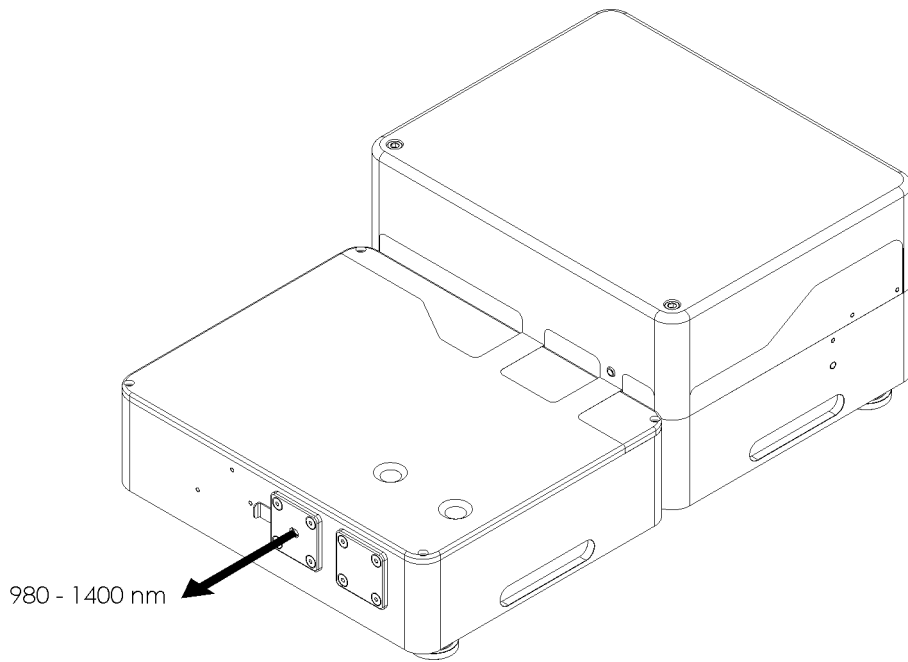

**Figure 11** FemtoFiber® pro SCIR continuum in dependence of prism position

By adjusting the motorized prism compressor (see section 5.4.3), the continuum can be altered to achieve a certain light intensity at a certain wavelength. This is illustrated in Figure 11.

### 1.2.5 Ultra Compressed Pulse System FemtoFiber<sup>®</sup> pro UCP

The FemtoFiber<sup>®</sup> pro UCP (Ultra Compressed Pulse) is the first model of the extended versions of TOPTICA's FemtoFiber<sup>®</sup> pro series. It comprises a very rugged master-oscillator with a power amplifier in a very compact design. Two motorized prism compressors are integrated: One for tuning the wavelength by adjusting the frequency-domain supercontinuum characteristics and a second for compressing and optimizing the time-domain laser pulse shape.



**Figure 12** FemtoFiber<sup>®</sup> pro UCP laser beam

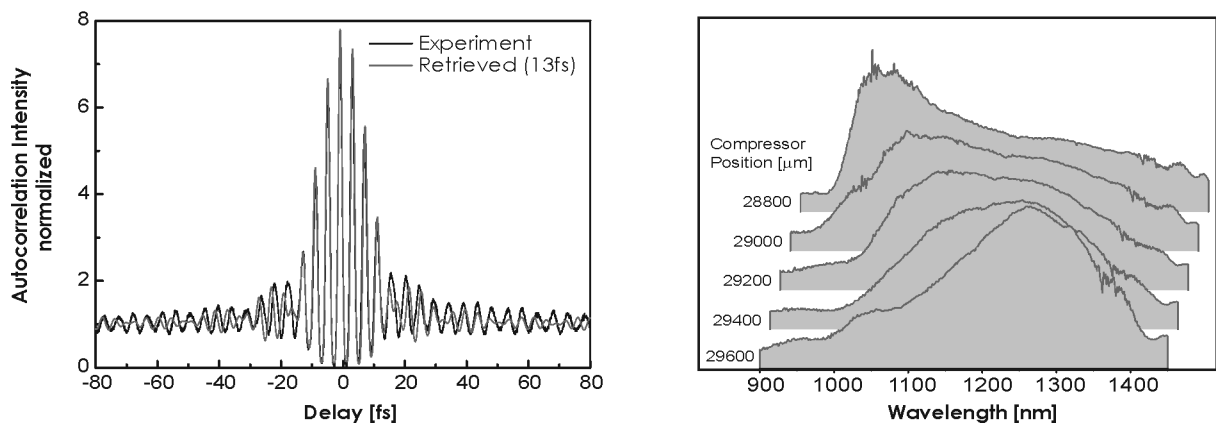
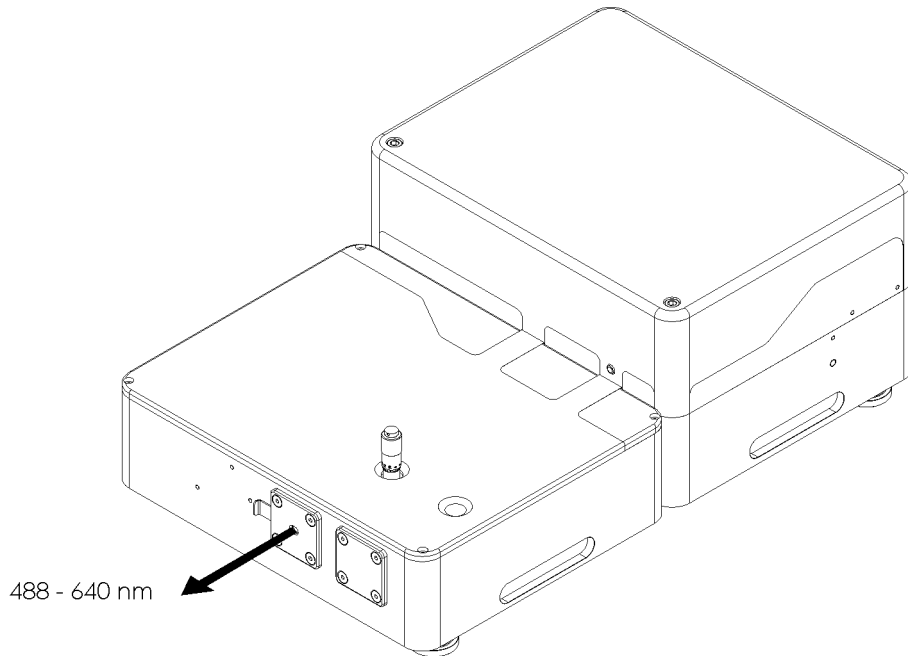

**Figure 13** Typical Pulse characteristics and emission spectrum of FemtoFiber<sup>®</sup> pro UCP



### 1.2.6 Tunable Visible System FemtoFiber® pro TVIS

The FemtoFiber® pro TVIS (Tunable VISible) is a further extension of the previously described UCP system. The compressed continuum is getting frequency-doubled into the visible light region by a following non-linear crystal. The crystal unit allows a continuous manual fine-tuning of the wavelength by a fine thread screw from 488 to 640 nm.



**Figure 14** FemtoFiber® pro TVIS laser beam

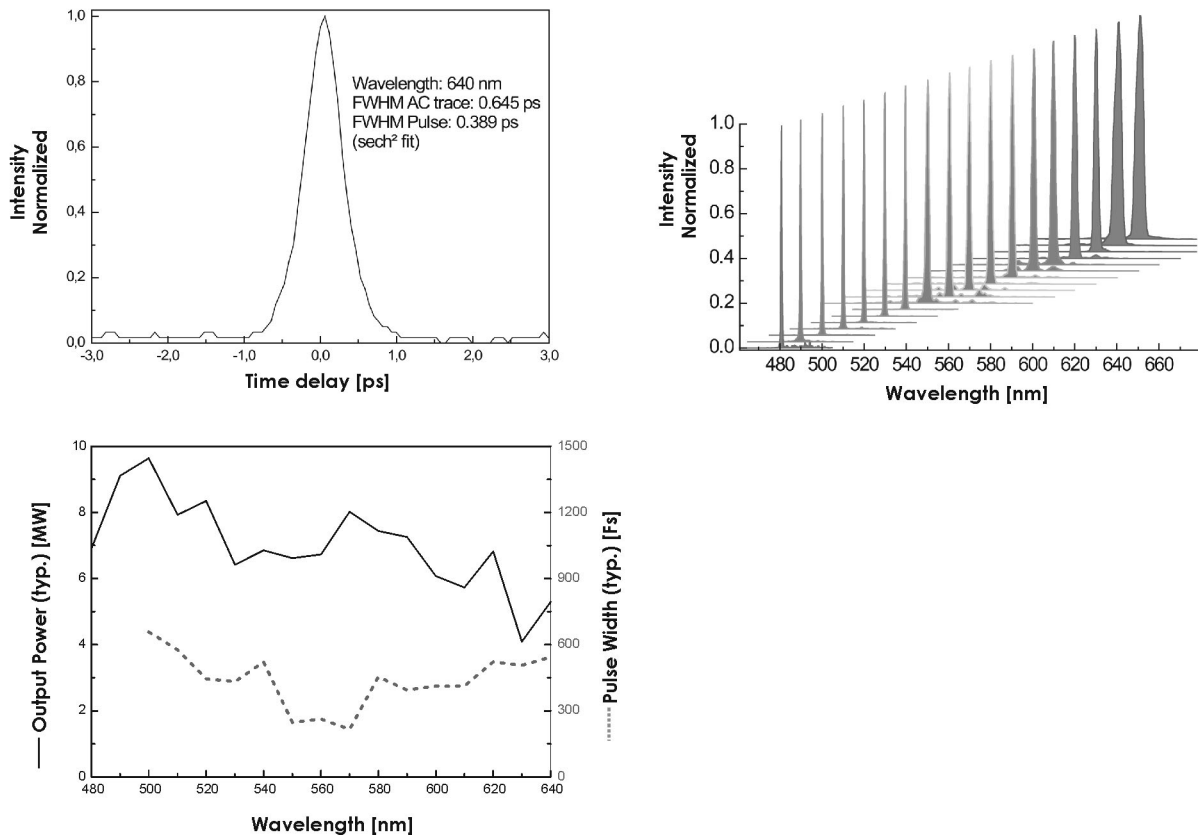
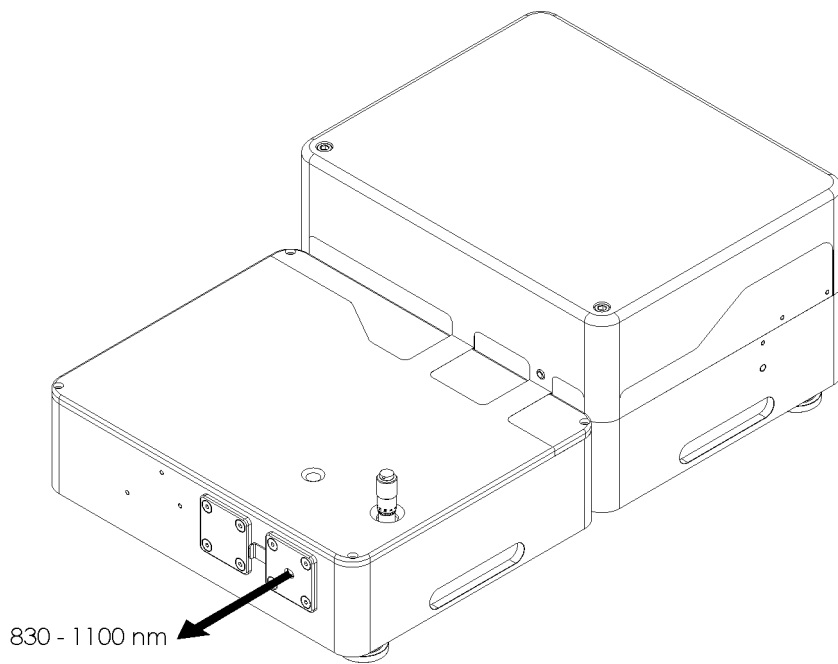

**Figure 15** Typical pulse characteristics, emission spectra and power distribution of the tunable FemtoFiber® pro TVIS system

### 1.2.7 Tunable Near Infrared System FemtoFiber® pro TNIR

The FemtoFiber® pro TNIR (Tunable Near-InfraRed) allows frequency doubling of the long wavelength part of the supercontinuum. This part of the continuum is solitonic, hence does not need any re-compression. The frequency-doubling nonlinear crystal is placed in the extension of the laser system and allows a continuous manual fine-tuning of the wavelength by a fine thread screw from 830 to 1100 nm.

As an option it is possible to combine the TNIR with an UCP or TVIS in the same housing. One has to take into account that the optimization of the properties of such combined outputs is not independent from each other, as they have the same continuum source.



**Figure 16** FemtoFiber® pro TNIR laser beam

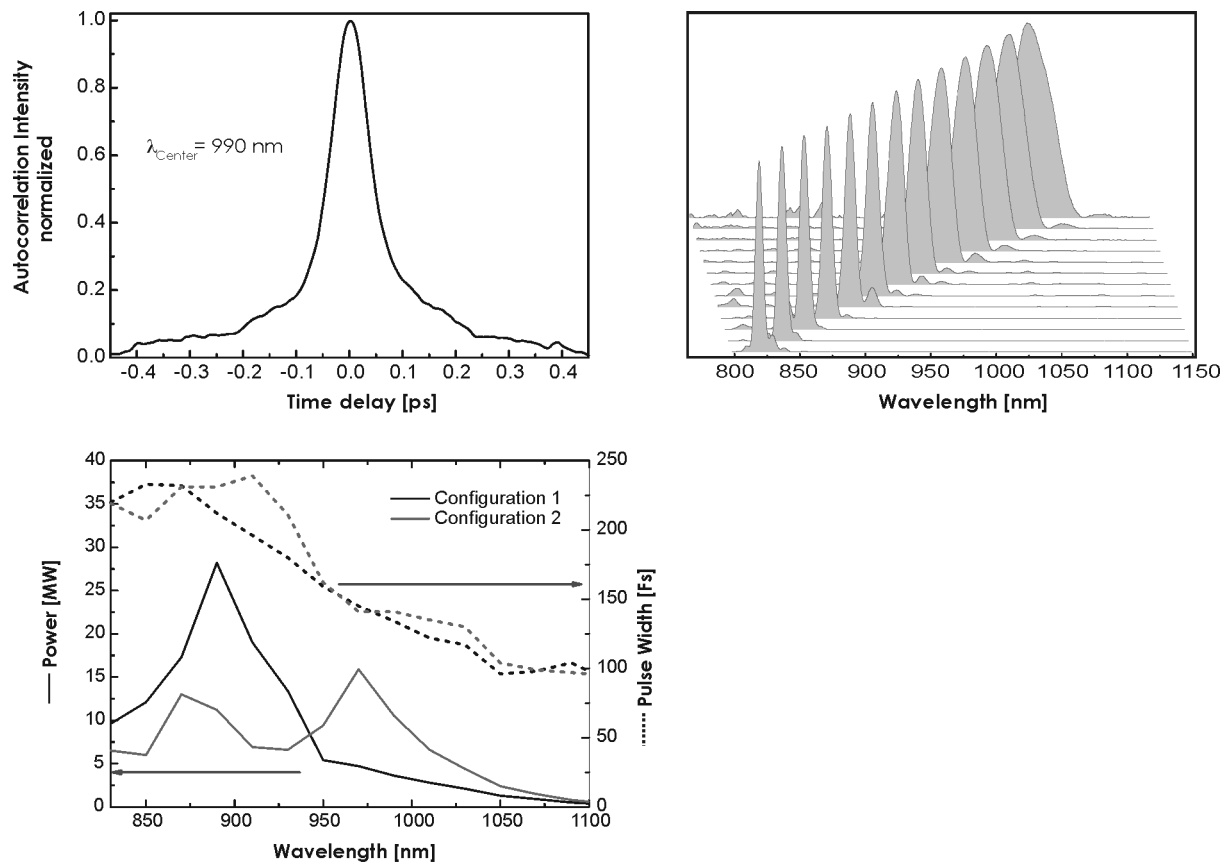

**Figure 17** Typical pulse characteristics, emission spectra and power distribution of the tunable FemtoFiber<sup>®</sup> pro TNIR system, available in two configurations

### 1.2.7.1 Configurations and 1 ps Option FemtoFiber® pro TNIR

#### Configurations

The FemtoFiber® pro TNIR laser head is available in two different configurations which allow to modify the power spectrum. Configuration 1 is enhancing the output power in the lower wavelength range 830 .. 950 nm with higher power (up to 20 - 30 mW for selected wavelengths, see Figure 17, lower graph, left y-axis). Configuration 2, in comparison, is lower in power (10 - 15 mW typical), but wider distributed in wavelength up to 1050 nm.

**NOTE !** Power levels above 1050 nm are typically in the range of 0.5 to 1 mW for all TNIR systems. It is not possible to increase the output power in this range, since the original supercontinuum does not have enough power in that range.

#### 1 ps Option

Instead of the typical 100 .. 250 fs pulse width as shown in Figure 17, lower graph, right y-axis, the system can be equipped with special crystals in order to allow broader pulses in the range of 0.5 to 1 ps instead. In case this option is ordered, the regular crystal is not included, but exchanged to a two-crystal design, where the first crystal works from 850 to 940 nm and the second from 940 to 1100 nm.

**NOTE !** The 1 ps option consists of two crystal mounts carrying two different crystals (crystal 1: 850 .. 940 nm, crystal 2: 940 .. 1100 nm). The procedure how to change the crystal mounts is shown in the installation training.  
The 1 ps option replaces the regular SHG crystal, which is not available anymore when this option is added.  
Continuous tuning from 940 to 1100 nm is not possible with the 1 ps option, as the crystal needs to be exchanged manually.

**NOTE !** The two mentioned FemtoFiber® pro TNIR laser head configurations of the output power distribution are also available for the 1 ps pulse option.

## 1.3 Options

### 1.3.1 Multi-Arm Laser System (Suffix AMP)

In order to allow multibeam experiments with synchronized beams originating from one common oscillator, FemtoFiber® pro systems are scalable as master-slave configurations with up to 3 slave lasers. Those AMP systems differ from the master system by the missing oscillator unit and a fiber input port instead. The product id suffix for such FemtoFiber® pro systems is "AMP".

**NOTE !** FemtoFiber® pro AMP systems (slaves) are not able to run as stand-alone. It is however safe to switch them ON even without having an oscillator electrically connected. The system is capable to detect this status and disables laser operation while the missing oscillator state is detected. The state is also permanently polled during normal operation.

### 1.3.2 Third/Fourth Arm for Seeding Extensions

FemtoFiber® pro standard systems with internal oscillator always have integrated a secondary oscillator arm (arm 1) with an FC/APC fiber output port. This exit is needed for seeding AMP systems (see section 1.3.1). So, by default, it is possible to run one AMP system without any additional option needed.

To provide more exit ports for more than one AMP system, it is however necessary to modify the oscillator accordingly. TOPTICA Photonics AG offers optional oscillator arms (arm 2 and arm 3), also comprising FC/APC fiber connectors.

**NOTE !** An internal oscillator arm (arm 0) is used to seed the internal amplifier of the master system. The exit ports therefore are named arm 1, 2 and 3.

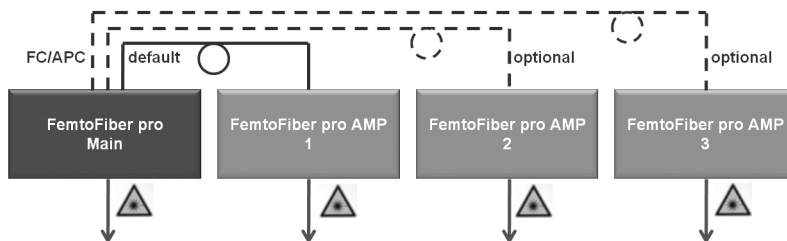

**Figure 18** FemtoFiber® pro main (master) system with 3 AMP (slave) systems

Figure 18 illustrates the scalability of the FemtoFiber® pro systems. Each of the boxes shown represents a FemtoFiber® pro system.

### 1.3.3 Oscillator Repetition Rate 40 MHz or Customized (Suffix M40 or MCUST)

The standard repetition rate of all FemtoFiber® pro systems is 80 MHz. Upon request, an optional 40 MHz design is also available. The product id suffix for such FemtoFiber® pro systems is "M40".

Furthermore, if an individually designed FemtoFiber® pro system with a certain repetition rate different from 40 or 80 MHz has been ordered, the product id shows the suffix "MCUST". The repetition rate is then noted on the laser beam classification label, see section 2.2.2.

**NOTE !** The repetition rate is a factory-set parameter and is fixed by the opto-mechanical oscillator and amplifier designs.

**NOTE !** This option is not available for the FemtoFiber pro IRS. It can also be added to multi-arm systems (as long as no FemtoFiber pro IRS/IRS AMP is involved).

### 1.3.4 Variable Laser Repetition Rate (Suffix VAR)

The option VAR (Variable Repetition Rate) enables the user to synchronize the repetition rate of the FemtoFiber® pro Laser with an external reference signal. This task is achieved by actively controlling the length of the laser cavity, which in turn determines the round-trip time of the oscillating light pulse.

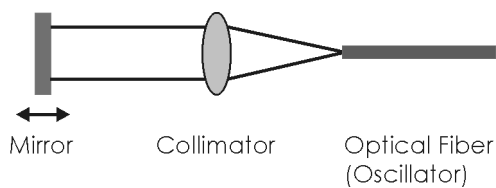

**Figure 19** Optical setup of the VAR-option

The fiber laser oscillator has a small free beam section with an adjustable mirror which reflects the light back into the fiber path (see Figure 19). This mirror is movable and varies the repetition rate by changing the resonator length. The movement of the mirror is controlled by a two step configuration for coarse and fine adjustment of the repetition rate.

Coarse adjustment is done by a piezo-motor driven, miniature translation stage. It has a maximum movable range of about 8 mm in total, approx.  $\pm 4$  mm from the mid position in both directions. The mid position corresponds to the nominal oscillator repetition rate noted in the Production and Quality Control Test Data Sheet. The maximum length variation corresponds to  $\pm 100$  kHz of repetition rate variation with respect to the nominal repetition rate.

Fine adjustment is performed by an additional high-voltage piezo with a maximum voltage up to 150 V. This piezo moves max. 10  $\mu\text{m}$  when the maximum Voltage of 150 V is applied. This corresponds to a change of the repetition rate of approx. 0.1 kHz. The piezo has a resonance frequency of 5 kHz.

**NOTE !** Option VAR can not be combined with option M40.

### 1.3.5 Laser Repetition Rate Control (Suffix LRC)

The LRC option enables the user to synchronize the repetition rate of the FemtoFiber® pro Laser with an external reference signal. This task is achieved by actively controlling the length of the laser cavity, which in turn determines the round-trip time of the oscillating light pulse.

Fast control action is obtained via a piezo-electric transducer onto which one of the fiber-optic beam collimators within the laser cavity is mounted. In this way, the piezo can control the length of the oscillator's free-beam section while the optical path length inside the fiber section remains unaffected. In addition, the entire unit including the piezo and the collimator is mounted on top of an automated translation stage, providing the opportunity for coarse adjustment of the repetition rate. This mechanism allows to correct for slow drifts in the repetition rate where the limited stroke of the piezo is not sufficient.

Apart from the servo elements which are mounted inside the laser head (VAR option), the LRC option adds four electronic plug in modules, placed inside a separate 12" supply rack, and a laptop computer for operation control and monitoring.

<b>NOTE !</b> Option LRC also requires option VAR installed in the laser system.
--



### 1.3.6 TNIR Secondary Output for UCP and TVIS (Suffix TNIR)

For the two system variants FemtoFiber pro TVIS and FemtoFiber pro UCP, the second-harmonic generation setup which is originally used in the FemtoFiber pro TNIR can be optionally added. This allows to have both units in a single box.

**NOTE !** As both outputs, TNIR and UCP/TVIS of such a combined system utilize the same supercontinuum source, both outputs are not independently adjustable.

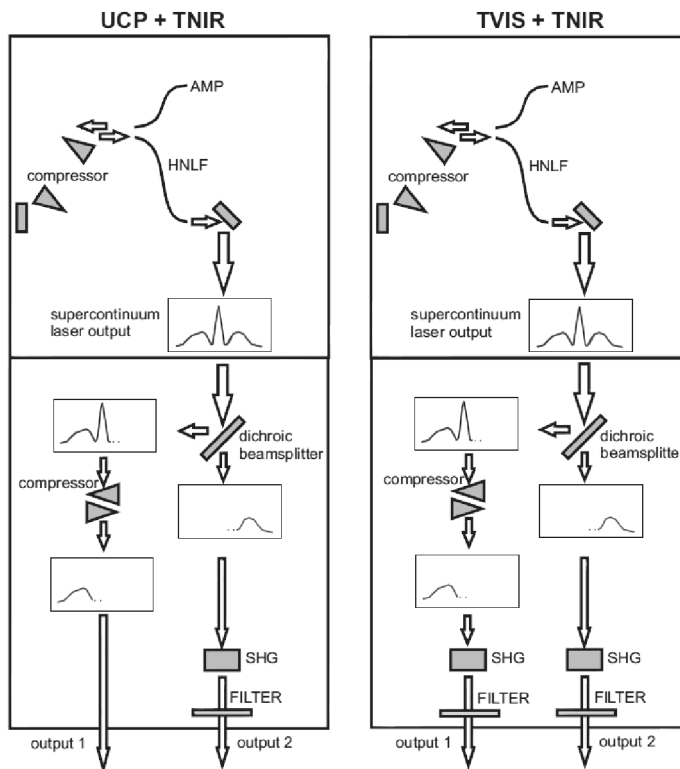

**Figure 20** Schematic setup for TNIR-option (UCP, TVIS)

**NOTE !** The TNIR-option is equal to an individual FemtoFiber pro TNIR system, therefore allowing also all special TNIR configurations and the options described in section 1.2.7.1.

## 2 Safety Instructions and Warnings

### 2.1 General Safety Terms

The FemtoFiber<sup>®</sup> pro Laser System Laser Head is manufactured according to the Laser Safety Standard EN 60825-1:2007 and complies with US laws 21 CFR §1040.10 and §1040.11.

**The following safety terms are used in this manual:**

The **DANGER !** heading in this manual explains danger that could result in personal injury or death. The **CAUTION !** heading in this manual explains hazards that could damage the instrument. In addition, a **NOTE !** heading provides information to the user that may be beneficial in the use of the instrument.

**DANGER !** Before operating the FemtoFiber<sup>®</sup> pro Laser System please read this manual carefully to prevent damage to the device, connected laser diodes and injury to persons. The following safety instructions must be followed at all times.

**DANGER !**  **Possibility of electrical shock !** Wherever this symbol is attached, the possibility of an electrical shock may appear. Use only equipment and accessories supplied by TOPTICA.

 **Caution !** Wherever this symbol is attached read and understand the manual before operating the device. The manual must be consulted in order to find out the nature of the potential HAZARDS and any actions which have to be taken to avoid them.

**DANGER !** The Laser Driver Electronics and the Laser Head each are equipped with LEDs which indicate laser emission. (Please refer to sections 4.1 and 4.2 in this manual for detailed information). **CAUTION !** One has to be aware of laser emission when at least one of these LEDs lights up.

**DANGER !** During installation, maintenance and service, all persons in the room must wear appropriate laser safety goggles while the laser is in operation. The recommended protection stage is dependent on the laser system. Use appropriate eyewear and other protective means in order to keep radiation exposure below the maximum permissible levels allowed by applicable regulations (examples: OSHA limits in the US, BGV B2, BGI5092, TROS Laserstrahlung in Germany). To determine the protection level of laser safety goggles required for e.g. a FemtoFiber<sup>®</sup> pro NIR laser system, please refer to the following example: FemtoFiber<sup>®</sup> pro NIR at 780 nm with collimated beam, beam diameter 1.2 mm, wavelength = 780 nm, repetition rate 80 MHz, laser power up to 170 mW generates a peak power density of  $H_M \sim 2.125 \text{ mJ/m}^2$  (approximately). From Table 3 in BGI5092 this leads to a required protection level of 780 D LB 5 + M LB 2 for your eyewear.

**DANGER !** Laser safety goggles selected for adjustment purposes do not protect against an intentionally focused direct beam which will increase the optical power densities by a few orders of magnitude.

- DANGER !** Regular functional checks and performance inspections at the supplier are recommended for all laser safety goggles.
- DANGER !** Do not position the equipment so that it is difficult to operate the disconnecting device.
- DANGER !** Use of controls or adjustments or performance of procedures other than those specified herein may result in hazardous radiation exposure.
- DANGER !** If the equipment is used in a manner not specified by the manufacturer, the protection provided by the equipment may be impaired.
- DANGER !** For safe operation and for proper grounding please use only the delivered mains supply cable. Improper or missing grounding can lead to serious injury.
- DANGER !** The electrical units should not be operated in a hazardous environment.
- DANGER !** **Do not open the FemtoFiber® pro Laser Head or Control Unit. There are no user serviceable parts inside.**
- DANGER !** Do not look into any exiting beam of the FemtoFiber® pro Laser Head as the output can exceed the limits for class 1 specified by the US laws 21 CFR 1040.10 and 2 CFR 1040.11 and the Laser Safety Standard EN 60825-1:2007. Take precautions to eliminate exposure to a direct or reflected beam.
- DANGER !** The FemtoFiber® pro Laser Head uses very powerful lasers (up to class 3B). Therefore, it is imperative to take great care and observe the statutory warning labels on the unit. In order to set up a door-interlock, the FemtoFiber® pro Control Unit has a connector at the rear panel. By using an appropriate door switch, the mains supply can be cut, and thus the diode laser is turned off.

## 2.2 Safety Labels

### 2.2.1 Protective Housing

The FemtoFiber® pro Laser Head has a protective cover fixed by screws. This cover should not be removed by the customer, there are no user serviceable parts inside.

**DANGER !** While the cover is removed for maintenance or service, the laser current must be reduced to laser power of Class 1 level or switched off completely. With removed cover the laser may emit stray light which is a health hazard to the eyes - protective eye wear is necessary ! Avoid exposing eyes and skin to the laser beam, including any laser stray light !

Depending on the specification of the FemtoFiber® pro Laser Head, the appropriate of the following labels is affixed to the FemtoFiber® pro protective cover according to EN 60825-1:2007

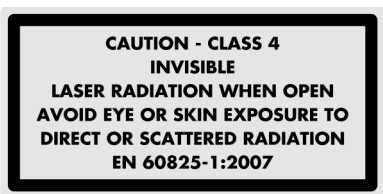
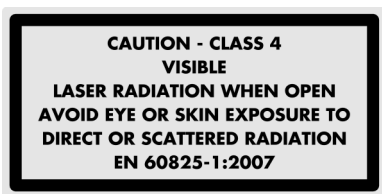

Size: 52 mm x 26 mm  
 Color: yellow/black  
 Location: FemtoFiber® pro Laser Head protective cover

### 2.2.2 Laser Beam

The FemtoFiber® pro Laser Head contains a fiber laser which, depending on the variant and options, emits visible or/and invisible pulsed laser radiation of less than 500 mW power (classified as Class 3 B laser product). The maximum power and the laser class of the FemtoFiber® pro Laser Head is indicated on the label shown below.

**DANGER !** The FemtoFiber® pro Laser Head, depending on the options, emits visible or/and invisible pulsed laser radiation of less than 500 mW power (Class 3 B laser product). Avoid exposing eyes and skin to the laser beam, including any laser stray light !

Depending on the specifications of the FemtoFiber® pro Laser System, the appropriate of the following label is affixed to the protective housing of the FemtoFiber® pro Laser Head according to EN 60825-1:2007:

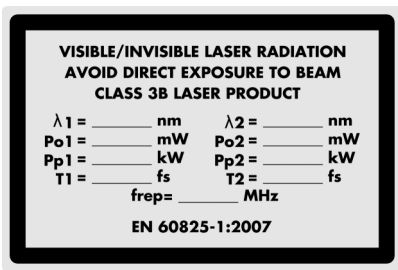

Size: 53 mm x 35 mm  
 Color: yellow/black  
 Location: FemtoFiber® pro Laser Head connector side

### 2.2.3 Apertures

During operation, the laser beam is emitted through one or two apertures located on the aperture plates and one or more FC/APC connector(s). The apertures and FC/APC connector(s) are marked by the labels shown below. The apertures can be closed by an aperture shutter (see section 2.5.2). The FC/APC connectors are closed by a cap.

**DANGER !** Through the apertures the FemtoFiber® pro Laser Head, depending on the options, emits visible or/and invisible pulsed laser radiation of less than 500 mW power (Class 3 B laser product). The maximum power and the laser class of the FemtoFiber® pro Laser Head is indicated on the label shown in section 2.2.2. Avoid exposing eyes and skin to the laser beam, including any laser stray light !

The following labels are affixed according to EN 60825-1:2007:

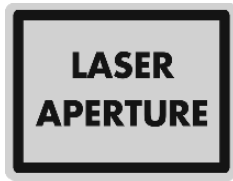

Size: 18 mm x 13 mm  
 Color: Yellow/black  
 Location: FemtoFiber® pro Laser Head next to the aperture(s) and the FC/APC connector(s)



Size: 25 mm x 25 mm  
 Color: Yellow/black  
 Location: FemtoFiber® pro Laser Head housing

### 2.2.4 CFR Compliance

Compliance with US laws 21 CFR §1040.10 and §1040.11 is declared by the following label:

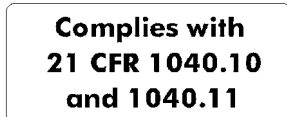

Size: 6 mm x 15 mm  
 Color: silver/black  
 Location: FemtoFiber® pro Laser Head housing

## 2.3 Identification of Manufacturer

Manufacturer (name and address), serial number, compliance with CE standards and Product ID number are noted on the identification labels:

### 2.3.1 FemtoFiber® pro Control Unit

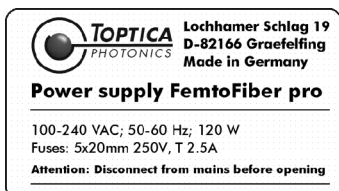

Size: 60 mm x 34 mm  
 Color: Silver/black  
 Location: Rear Panel FemtoFiber® pro Control Unit

Size: 38 mm x 19 mm  
 Color: Silver/black  
 Location: Rear Panel FemtoFiber® pro Control Unit

### 2.3.2 FemtoFiber® pro Laser Head



Size: 38 mm x 19 mm  
 Color: Silver/black  
 Location: FemtoFiber® pro Laser Head

## 2.4 Identification Labels

Each FemtoFiber® pro Laser Head must be connected to its dedicated Control Unit. FemtoFiber® pro Laser Head and Control Unit are respectively marked by serial number containing labels for easier identification:



Size: 56 mm x 10 mm  
 Color: Silver/black  
 Location: FemtoFiber® pro Laser Head and FemtoFiber® pro Control Unit

## 2.5 Safety Features of the FemtoFiber® pro Laser System

### 2.5.1 External Interlock

The FemtoFiber® pro Control Unit provides the user with an interlock connector located at the rear panel (see Figure 29). In case of an interlock, the laser head controlled by the respective FemtoFiber® pro Control Unit is disabled.

**NOTE !** To switch ON the FemtoFiber® pro Laser System after a switch-OFF by the external interlock, the Start/Stop button on the FemtoFiber® pro Control Unit front panel must be pressed to switch the system ON again. Alternatively the system can be switched ON again by clicking the **ON button** in the *Laser Control Tab* of the FemtoFiber® pro GUI, or using the software command: `ffpro.armX.on()`. X represents 0 for the main system or 1, 2, 3 for the AMP system(s).

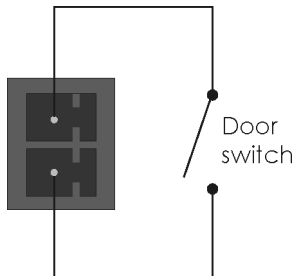
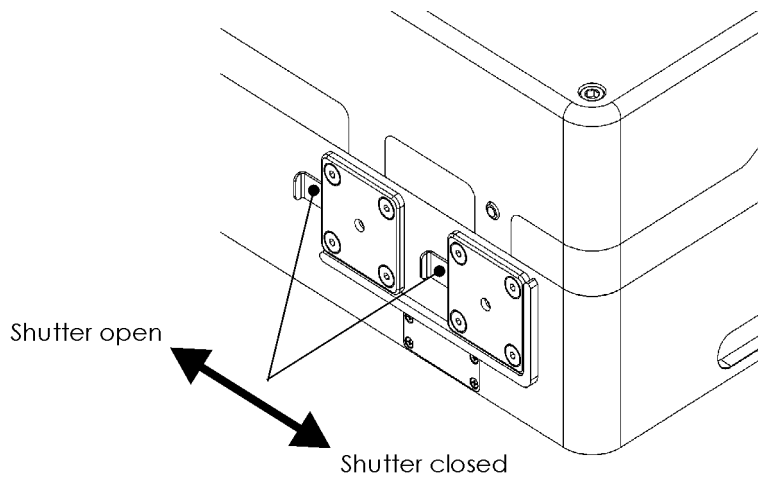

**Figure 21** Interlock connector

To install an external interlock circuit, please remove the wire in the supplied interlock plug (Phoenix Contact MC 1.5/2-ST-3.81) and connect the interlock circuit.

**NOTE !** With a **Multi-Arm Laser System**, each Control Unit needs an own interlock circuit.

## 2.5.2 Laser Beam Shutter



**Figure 22** FemtoFiber® pro laser head aperture shutter

**DANGER !** Do not look into any exiting beam of the FemtoFiber® pro Laser Head as the output can exceed the limits for class 1 specified by the US laws 21 CFR 1040.10 and 2 CFR 1040.11 and the Laser Safety Standard EN 60825-1:2007. Take precautions to eliminate exposure to a direct or reflected beam.

The laser beam apertures of the FemtoFiber® pro Laser Head each have a manual laser beam shutter to block the exiting beam. To operate the shutter, shift the shutter as shown in Figure 22. Check with a suitable IR-card whether the laser beam is blocked or not.



### 2.5.3 Fuses

The connector block contains two fuses and is located at the rear panel of the FemtoFiber<sup>®</sup> pro Control Unit.

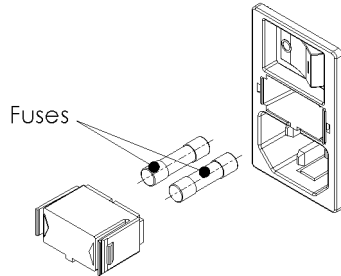

**Figure 23** Fuses at FemtoFiber<sup>®</sup> pro control unit connector block

To replace the fuses, open the connector block cover as shown in Figure 23 and pull out the fuse holder. Use only Miniature Fuses 5 x 20 mm, T 2.5 A, 250 V.

**NOTE !** Both fuses are actively in use. Due to this, both fuses have to be checked !

### 3 Installation

#### 3.1 Inspection after Delivery

The FemtoFiber® pro Laser System is packaged in a carton designed to give maximum protection during shipment. If the outside of the shipping package is damaged, notify your shipping department immediately. The shipping agent may wish to notify the carrier at this point.

If the shipping carton is undamaged externally, all parts of the FemtoFiber® pro Laser System should be removed from the carton. If any damage is evident visually, notify TOPTICA Photonics AG and your shipping agent. It is recommended to save the carton for future storage or transportation.

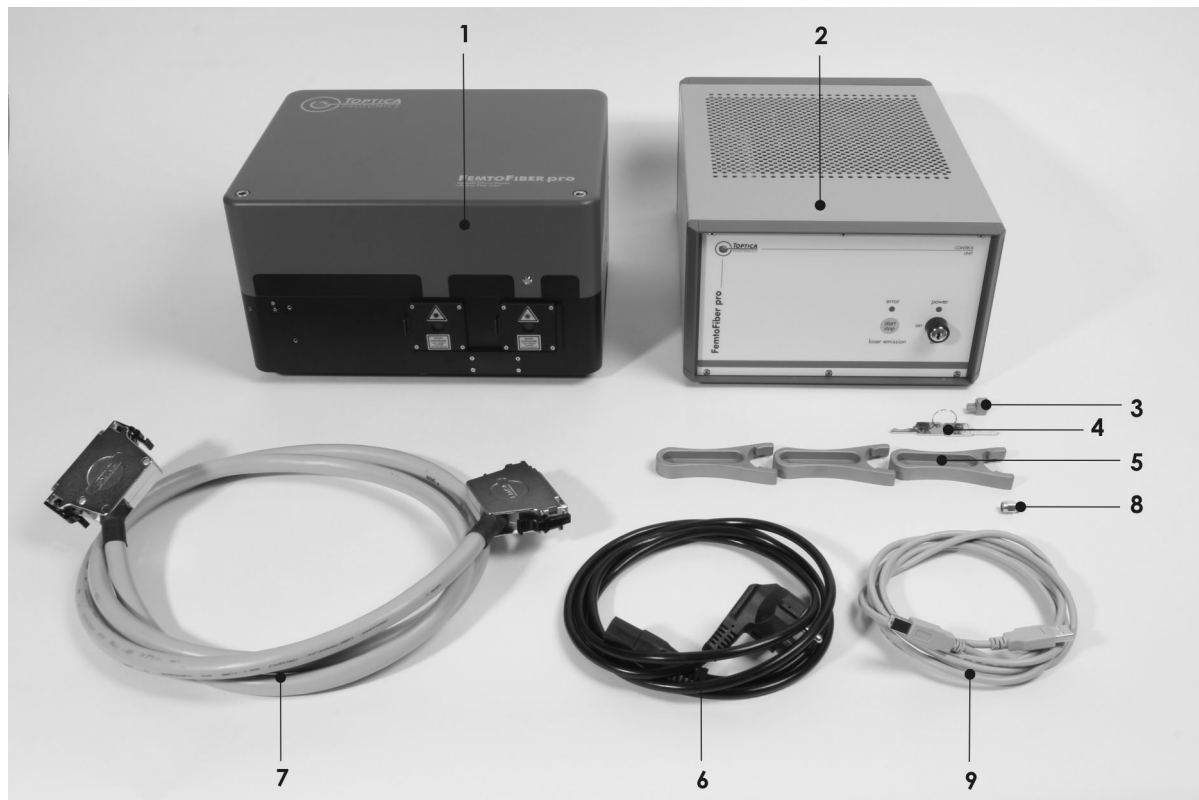

**Figure 24** Basic FemtoFiber® pro laser system

**The basic FemtoFiber® pro Laser System consists of the following parts:**

- 1 FemtoFiber® pro Laser Head
- 2 FemtoFiber® pro Control Unit
- 3 External interlock plug
- 4 2 Keys for key switch
- 5 3 Clamping forks
- 6 Mains supply cable
- 7 Connection cable for FemtoFiber® pro Laser Head connection to FemtoFiber® pro Control Unit (37 pin D-Sub)
- 8 50 Ω SMA terminator for Oscillator Monitor Output connector
- 9 USB cable
- 10 Software installation USB flash drive (not shown)
- 11 FemtoFiber® pro Manual (not shown)

**A two/three/four arm system consists of basic system with items 1..7 two/three/four times and**

- 12** one/two/three FC/APC fibers, each 1 m long
- 13** two/three/four Ethernet patchcords
- 14** Ethernet switch
- 15** Power supply for Ethernet switch incl. mains supply cable

**Additional items of a FemtoFiber® pro Laser System with VAR Option**

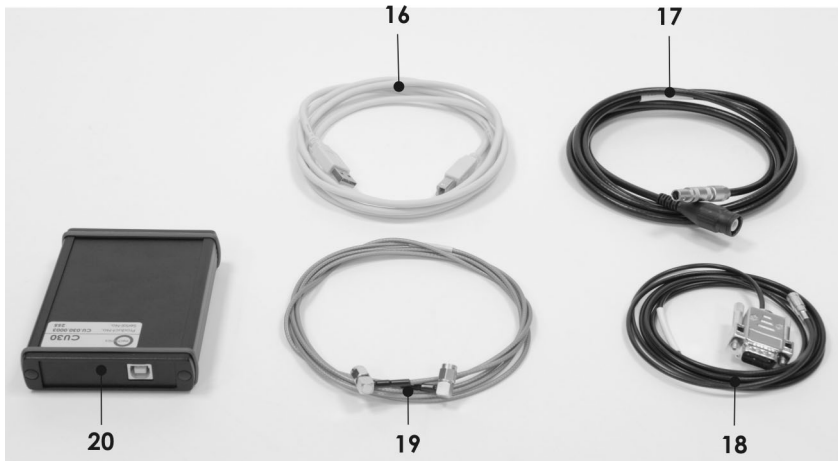

**Figure 25** Additional items FemtoFiber® pro laser system with VAR-option

- 16** USB cable for Mechanics Box
- 17** Lemo 2 pin to HV-isolated BNC cable for Piezo
- 18** SMB to D-Sub9 cable for Mechanics Box
- 19** SMA to SMA connection cable, 2 m long
- 20** Mechanics CU30 Driver Box
- 21** Software and Manual CD for Mechanics Box (not shown)

**Additional items of a FemtoFiber<sup>®</sup> pro Laser System with LRC Option**

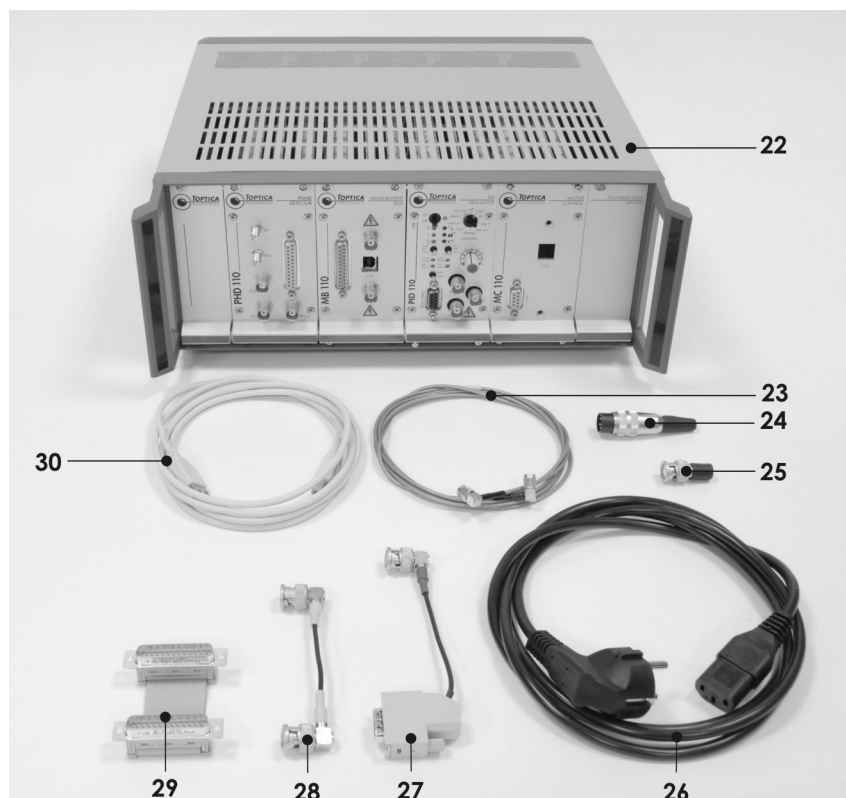

**Figure 26** Additional items FemtoFiber<sup>®</sup> pro laser system with LRC-option

- 22** 12" Supply Rack with 4 Plug in Modules (PHD 110, MB 110, PID 110, MC 110)
- 23** Additional SMA to SMA connecting cable, 2 m long
- 24** Interlock plug
- 25** 50  $\Omega$  BNC terminator for  $\Delta \Phi_{in}$  connector on PHD 110 module
- 26** Mains supply cable
- 27** BNC to D-SUB connecting cable, color code: red, approx. 15 cm long
- 28** BNC connecting cable, color code: yellow, approx. 10 cm long
- 29** Ribbon connecting cable, approx. 6 cm long
- 30** Additional USB connecting cable
- 31** Laptop computer with pre-installed software and drivers (not shown)
- 32** Software and Manual CD for *InstaCal* Measurement Box (not shown)

Depending on the individual order, your FemtoFiber<sup>®</sup> pro Laser System may be delivered with further options or items not listed here.

**NOTE !** If option LRC is ordered, item 20, Mechonics CU30 Driver Box, is integrated into the 12" Supply Rack as MC 110 module.

**NOTE !** Cables 27, 28 and 29 are usually factory pre-mounted to their dedicated positions at the modules of the 12" Supply Rack.

### 3.2 Installation Instructions FemtoFiber® pro Laser Head

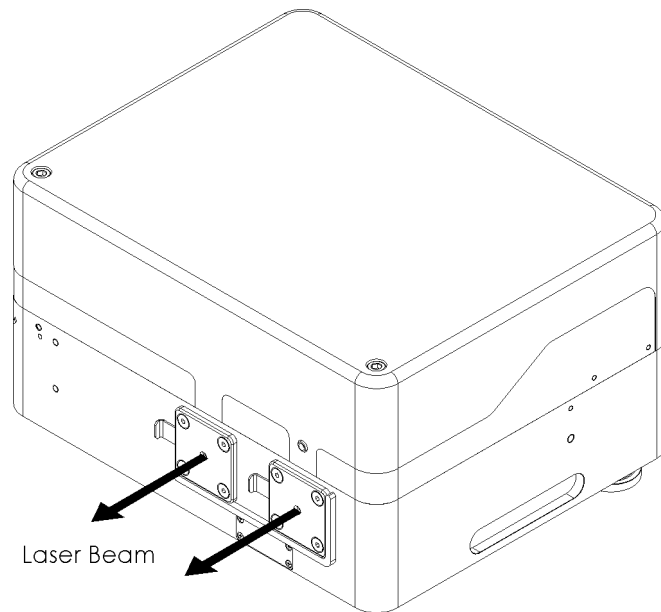

**Figure 27** FemtoFiber® pro laser head

When installing the FemtoFiber® pro Laser Head the following instructions have to be observed:

- The FemtoFiber® pro Laser Head must be fixed by brackets or clamping forks to a breadboard either at the protective housing or at the 3 posts (for main dimensions of the FemtoFiber® pro Laser Head please see section 6.11, for mounting options please see section 6.13).
- The FemtoFiber® pro Laser Head should only be installed in place free from vibrations.
- Environmental conditions:  
Operation temperature: +20 °C .. +30 °C, rel. humidity non condensing.  
Transport/storage temperature: 0 °C .. +40 °C, rel. humidity non condensing.
- Weights: Control Unit < 4.5 kg, FemtoFiber® pro laser head < 15 kg depending on system variant and options.
- Never use the FemtoFiber® pro Laser System near water, for example near a wash basin, a sink or other damp environment.
- The laser beam emits through up to one of the 2 apertures shown in Figure 27 depending on the system variant. For location of the laser beam apertures please see section 6.11.

**NOTE !** When not in use the Oscillator Monitor Output connector must be 50 Ω terminated by the supplied terminator.

- **Only use cables supplied by TOPTICA for connection between FemtoFiber® pro Laser Head and Control Unit. Use of other cables voids warranty.**

## 4 Operation

### 4.1 Operator Controls FemtoFiber<sup>®</sup> pro Laser Head

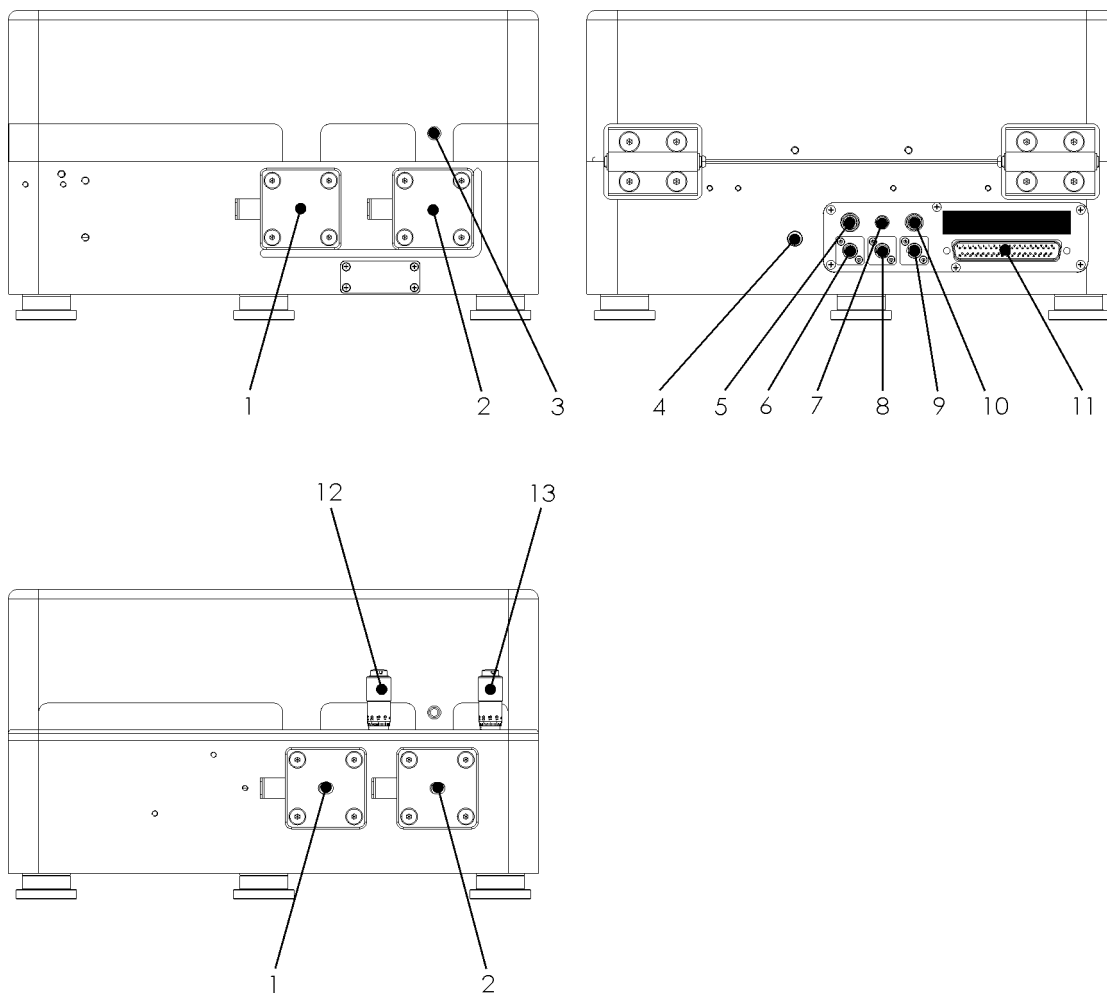

**Figure 28** Operator controls at FemtoFiber<sup>®</sup> pro laser head

- |   |  |  |
|---|--|--|
| <p><b>1</b> Secondary Aperture (only available with NIR/UCP/TVIS variants)</p> <p><b>2</b> Primary Aperture</p> <p><b>3</b> Laser Radiation Emission Warning LED</p> <p><b>4</b> 1560/780-Switch (only available with NIR variant)</p> <p><b>5</b> HV-Piezo (only VAR Option)</p> | <p><b>6</b> FC/APC Connector Arm 1</p> <p><b>7</b> Motor Stage (only VAR Option)</p> <p><b>8</b> FC/APC Connector Arm 2</p> <p><b>9</b> FC/APC Connector Arm 3</p> <p><b>10</b> Oscillator Monitor Output<br/>Only with VAR Option:<br/>RF-Sync Output</p> | <p><b>11</b> Power/Control Connector</p> <p><b>12</b> Only TVIS variant<br/>Manual Wavelength Tuning</p> <p><b>13</b> Only TNIR variant<br/>Manual Wavelength Tuning</p> |
|---|--|--|

### 4.1.1 Description of Operator Controls FemtoFiber® pro Laser Head

<b>1 Secondary Aperture (only available with NIR/UCP/TVIS variant)</b>	Secondary Aperture of the FemtoFiber® pro Laser Head: <b>NIR Variant:</b> 1560 nm frequency doubled laser beam. <b>UCP Variant:</b> 980 - 1400 nm supercontinuum laser beam. <b>TVIS Variant:</b> 488 - 640 nm tunable laser beam.
<b>2 Primary Aperture</b>	Standard Aperture of the FemtoFiber® pro Laser Head: <b>IR/IRS Variant:</b> 1560/1570 nm laser beam. <b>NIR Variant:</b> 780 nm frequency doubled laser beam. <b>SCIR Variant:</b> 980 - 2200 nm supercontinuum laser beam. <b>TNIR Variant/Option</b> 830 - 1100 nm tunable laser beam.
<b>3 Laser Radiation Emission Warning LED</b>	The white Laser Radiation Emission Warning LED lights up continuously when laser light is emitted under standard specifications. The LED is blinking when the laser is running with reduced power, i.e. not under standard specification (for adjustment of <i>set level</i> please see section 5.4.3). <b>DANGER !</b> When the white Laser Radiation Emission Warning LED lights up or is blinking, one has to be aware of laser emission.
<b>4 1560/780 Switch (only available with NIR variant)</b>	Mechanical switch to change between either 780 nm or 1560 nm laser beam (only NIR variant). <b>NOTE !</b> Both wavelengths simultaneously are not available.
<b>5 HV-Piezo (only VAR Option)</b>	Fine adjustment of the resonator length is performed by a high-voltage piezo. This piezo moves max. 10 µm when the maximum Voltage of 150 V is applied. This corresponds to a change of the repetition rate of approx. 0.1 kHz. The piezo has a resonance frequency of 5 kHz.
<b>6 FC/APC Connector Arm 1</b>	Fiber connector for seeding an external FemtoFiber® pro AMP Laser Head.
<b>7 Motor Stage (only VAR Option)</b> <ul style="list-style-type: none"> <li>• SMB-connector</li> </ul>	Coarse adjustment of the resonator length is performed by a translation stage. The mid position corresponds to the nominal oscillator repetition rate noted in the Production and Quality Control Test Data Sheet. The maximum length variation corresponds to ± 100 kHz of repetition rate variation with respect to the nominal repetition rate.
<b>8 FC/APC Connector Arm 2</b>	<b>Multi Arm System with 3 arms:</b> Fiber connector for seeding an external FemtoFiber® pro AMP Laser Head
<b>9 FC/APC Connector Arm 3</b>	<b>Multi Arm System with 4 arms:</b> Fiber connector for seeding an external FemtoFiber® pro AMP Laser Head
<b>10 Oscillator Monitor Output</b> <b>Only with VAR Option:</b> <b>RF-Sync Output</b> <ul style="list-style-type: none"> <li>• SMA-connector</li> </ul>	Connector for pulse-train monitoring on an oscilloscope (min. 200 MHz) or a spectrum analyzer. Any device connected must be 50 Ω terminated. <b>NOTE !</b> When not in use the connector must be 50 Ω terminated by the supplied terminator. <b>Only with VAR Option:</b> RF output for synchronization of the repetition rate.
<b>11 Power/Control Connector</b> <ul style="list-style-type: none"> <li>• D-Sub 37-pin male connector</li> </ul>	Connector for control and supply of the FemtoFiber® pro Laser Head by the FemtoFiber® pro Control Unit via the supplied connection cable.
<b>12 TVIS Manual Wavelength Tuning</b>	Manual Wavelength Tuning (only TVIS variant) For details of fine thread screw settings and corresponding values please refer to the TVIS section of the Production and Quality Control Data Sheet.
<b>13 TNIR Manual Wavelength Tuning</b>	Manual Wavelength Tuning (only TNIR variant) For details of fine thread screw settings and corresponding values please refer to the TNIR section of the Production and Quality Control Data Sheet.

## 4.2 Operator Controls FemtoFiber® pro Control Unit

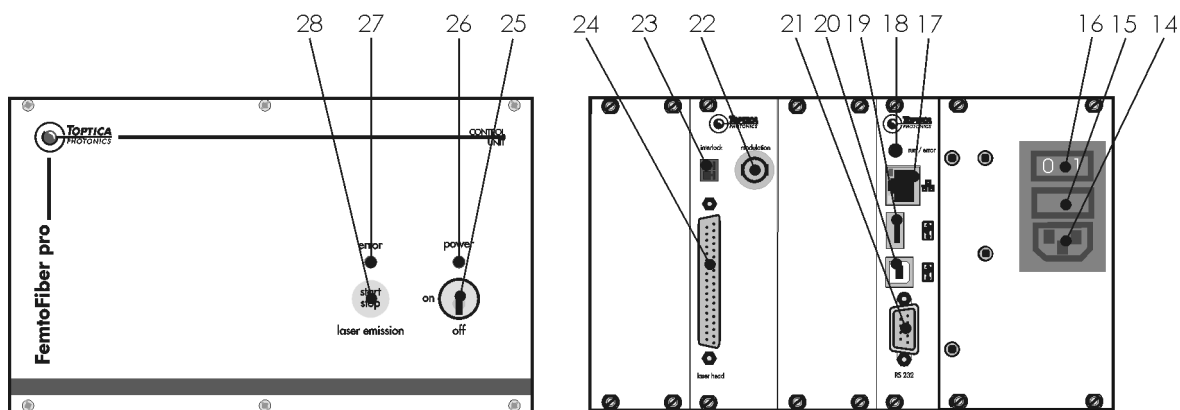

**Figure 29** Operator controls FemtoFiber® pro Control Unit

**NOTE !** The operator controls for the mode-locked ring oscillator and the one or two non-linear fiber amplifiers (depending on the specification) are identical and described only once.

- |                                     |                                |   |
|-------------------------------------|--------------------------------|---|
| <b>14</b> Mains Connector           | <b>19</b> USB Type A Connector | <b>24</b> Power/Control Connector   |
| <b>15</b> Fuse Holder               | <b>20</b> USB Type B Connector | <b>25</b> ON/OFF Key Switch   |
| <b>16</b> Mains ON/OFF Switch       | <b>21</b> RS232 Connector      | <b>26</b> Power Status LED  |
| <b>17</b> TCP/IP Ethernet Connector | <b>22</b> reserved             | <b>27</b> Error LED (red/green)   |
| <b>18</b> Error LED (red)           | <b>23</b> Interlock Connector  | <b>28</b> Laser Emission Start/Stop Button and Laser Radiation Emission Warning LED |



### 4.2.1 Description of Operator Controls FemtoFiber® pro Control Unit

<b>14 Mains Connector</b>	Socket for connection to the mains line via the supplied mains cable.
<b>15 Fuse Holder</b>	For changing the fuses please see section 2.5.3. Use only Miniature Fuse 5 x 20 mm, T 2.5 A, 250 V. <b>NOTE !</b> Both fuses are actively in use. Due to this, both fuses have to be checked !
<b>16 Mains ON/OFF Switch</b>	ON/OFF switch for the mains supply of the FemtoFiber® pro Control Unit.
<b>17 TCP/IP Ethernet Connector</b>	Ethernet connector for computer control.
<b>18 Error LED</b>	The LED blinks red while the internal microprocessor is booting and lights up green continuously when the internal microprocessor is ready for operation. The LED lights up red continuously when a severe error leading to a laser emission shut-down has occurred.
<b>19 USB Type A Connector</b>	USB 1.1 Interface connector for service purposes and firmware update.
<b>20 USB Type B Connector</b>	USB 1.1 Interface connector for computer control.
<b>21 RS232 Connector</b>	RS232 Interface connector for computer control.
<b>22 reserved</b>	
<b>23 Interlock Connector</b> • Phoenix connector	Connector for installation of an external interlock circuit. Please see section 2.5.1 for details. For installation use a Phoenix Contact MC 1.5/2-ST-3.81 plug.
<b>24 Power/Control Connector</b> • D-Sub 37-pin female connector	Connector for control and supply of the FemtoFiber® pro Laser Head by the FemtoFiber® pro Control Unit via the supplied connection cable.
<b>25 ON/OFF Key Switch</b>	Key Switch to switch the FemtoFiber® pro Control Unit ON/OFF. In position OFF the internal microprocessor is switched OFF and the internal power supply is in standby-mode.
<b>26 Power Status LED</b>	The green LED lights up continuously when the internal microprocessor is ready for operation. A slow blinking indicates that the system is in standby mode. The LED blinks fast while the internal microprocessor is booting. <b>NOTE !</b> The boot sequence must be finished before the laser can be started. This is indicated by an acoustic signal.
<b>27 Error LED</b>	Red LED indicating severe errors leading to a laser emission shut-down. Details about the error are displayed on the Console Tab of the FemtoFiber® pro GUI (see section 5.4.7). <b>NOTE !</b> In case of a severe error, please contact TOPTICA Photonics AG.
<b>28 Laser Emission Start/ Stop Button and Laser Radiation Emission Warning LED</b>	Push button to switch the laser ON/OFF. The yellow LED in the button lights up when laser light is emitted. <b>DANGER !</b> When the yellow Laser Radiation Emission Warning LED lights up, one has to be aware of laser emission.

## 4.3 Connection of the FemtoFiber® pro Laser System

**CAUTION !** Before plugging in the cables, make sure that the FemtoFiber® pro Control Unit is switched OFF at the ON/OFF Switch at the rear panel.

The following basic connections are necessary to operate the FemtoFiber® pro Laser System:

**NOTE !** When not in use, the Oscillator Monitor Output (10) must be 50  $\Omega$  terminated by the supplied terminator.

- 1 Connect the supplied mains cable to the FemtoFiber® pro Control Unit (connector and switch at rear panel, see Figure 29).
- 2 Connect the supply and control cable to the FemtoFiber® pro Laser Head (Power/Control Connector (11)) and the FemtoFiber® pro Control Unit (Power/Control Connector (24)).

**DANGER !** For your safety it is recommended to set up an external interlock circuit. If no interlock circuit is connected, please use the supplied interlock plug to close the external interlock circuit. For information see section 2.5.1. Make sure the interlock circuit is closed before operating the system. For safety reasons please close the laser beam shutter(s) as described in section 2.5.2.

- 3 For computer control of the FemtoFiber® pro system via USB please follow the instructions noted in section 5.1 to install the USB connection.

### 4.3.1 FemtoFiber® pro Multi-Arm Laser Systems

**CAUTION !** Before plugging in the cables, make sure that all FemtoFiber® pro Control Units are switched OFF at the ON/OFF Switch at the rear panel.

- 1 Connect the supplied mains cables to the FemtoFiber® pro Control Units (connector and switch at rear panel, see Figure 29).
- 2 Connect the supply and control cables to the FemtoFiber® pro Laser Heads (Power/Control Connector (11)) and the FemtoFiber® pro Control Units (Power/Control Connector (24)).

**NOTE !** Make sure that each FemtoFiber® pro Laser Head is connected to its dedicated Control Unit. FemtoFiber® pro Laser Head and Control Unit are respectively marked by serial number containing labels for easier identification (see section 2.4).

**DANGER !** For your safety it is recommended to set up an external interlock circuit. If no interlock circuit is connected, please use the supplied interlock plugs to close the external interlock circuits. For information see section 2.5.1. Make sure the interlock circuits are closed before operating the system. For safety reasons please close the laser beam shutter(s) as described in section 2.5.2.

- 3 Connect the FC/APC fibers for each arm (i.e. FemtoFiber® pro AMP Laser Head) to the respective FC/APC connector (Figure 28: 6, 8, 9) of the FemtoFiber® pro main Laser Head.

When not in use the FC/APC connector must be closed by the supplied cap(s) for laser safety reasons and to prevent from pollution.

- 4 Only 2, 3 and 4 arm systems:  
Connect the Control Computer to the USB Type A connector (Figure 29: 19) of the FemtoFiber<sup>®</sup> pro main Control Unit.  
Connect the Ethernet switch to the power supply. Connect the Ethernet switch to the FemtoFiber<sup>®</sup> pro Control Units by patchcords.

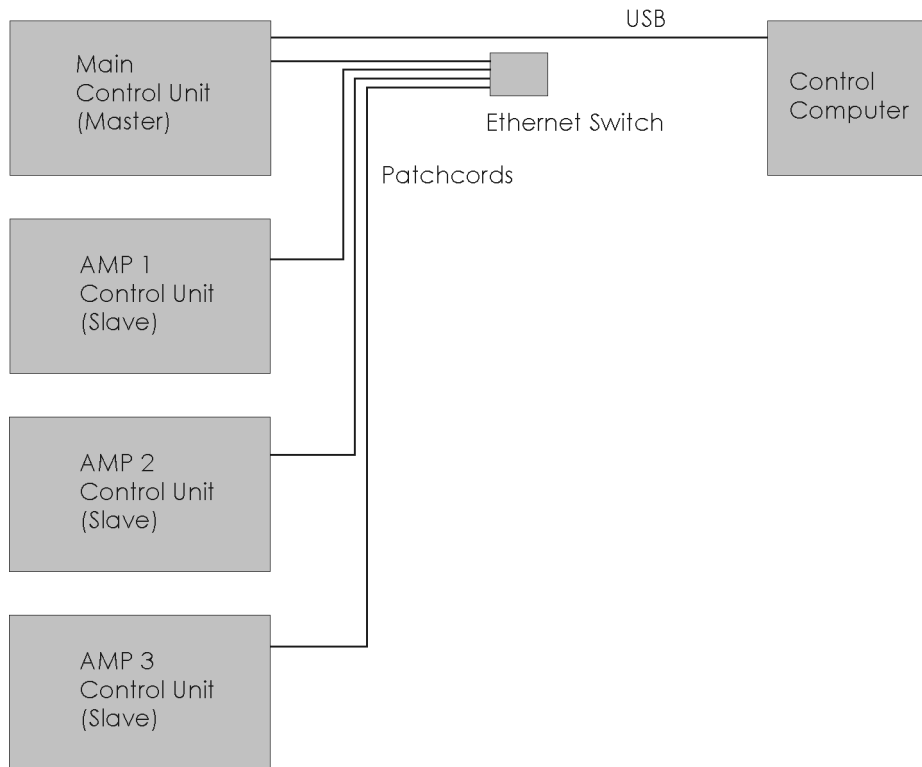

**Figure 30** FemtoFiber<sup>®</sup> pro 4 arm system

### 4.3.2 Additional Connections FemtoFiber<sup>®</sup> pro with VAR and LRC Option

Please refer to sections 6.2.2 and 6.3.2 in the appendix for additional connections of systems with VAR and LRC option.

## 4.4 Power Up of FemtoFiber® pro Systems

**DANGER !** Do not look into the exiting beam of the FemtoFiber® pro Laser Head as the output can exceed the limits for class 1 specified by the US laws 21 CFR 1040.10 and 2 CFR 1040.11 and the Laser Safety Standard EN 60825-1:2007. Take precautions to eliminate exposure to a direct or reflected beam.

**NOTE !** The FemtoFiber® pro Control Unit is equipped with an universal mains input which sets the FemtoFiber® pro Control Unit to your local mains supply voltage.

**NOTE !** The operation of systems with VAR option is described in section 6.2 in the appendix.

For safe operation of the FemtoFiber® pro Laser System please follow the steps below.

1. Make sure all connections according to section 4.3 are installed.
2. Switch ON the Mains Switch on the rear panel of the FemtoFiber® pro Control Unit(s) to set the system in standby mode.

**CAUTION !** With a **Multi-Arm Laser System**, for safety reasons and to guarantee optimum system performance, before powering-up always check whether the FC/APC fiber connections are installed properly.

3. Switch ON the FemtoFiber® pro Control Unit(s) by the Key Switch at the front panel and wait until the boot sequence is finished. This is indicated by an acoustic signal and the green Power Status LED lighting continuously.
4. **Manual Operation:**  
To activate/deactivate the laser(s) press the yellow Laser Emission Start/Stop button on the FemtoFiber® pro Control Unit(s) front panel.  
**Computer Controlled Operation:**  
Start the FemtoFiber® pro GUI(s) and connect each FemtoFiber® pro Control Unit as described in section 5.3. Click the **ON** or **OFF** button on the *Laser Control* Tab of the FemtoFiber® pro GUI to activate/deactivate the laser controlled by the respective GUI.
5. The white Laser Radiation Emission Warning LED (Figure 28: 3) lights up continuously and indicates laser emission.  
Open the desired shutter.

## 4.5 Power Down

**NOTE !** The operation of systems with VAR option is described in section 6.2 in the appendix.

1. To switch OFF the FemtoFiber® pro Laser System, deactivate the laser(s) at the respective yellow Laser Emission Start/Stop button on the FemtoFiber® pro Control Unit(s) front panel.
2. Switch OFF the FemtoFiber® pro Control Unit(s) by the Key Switch on the front panel.

## 5 Computer Control of the FemtoFiber® pro Laser System

### Key features:

- Built-in microprocessor for system control
- Easy communication through web browser
- Access to motorized controls, such as variable pulse compression
- Python command structure available for system integration

The FemtoFiber® pro Control Unit includes a microprocessor which controls all laser parameters. This ensures turnkey and hands-off operation with a single ON/OFF button for the user.

Standard communication interfaces (Ethernet, USB and RS 232) allow access to all relevant parameters for an easy integration in complex setups. The user can choose between three alternatives: Simplest way is to login via any web browser already installed on the user's computer. Another way is employing the FemtoFiber® pro GUI that is included free of charge. The advanced user may also write his own scripts using a pool of pre-defined Python commands.

### 5.1 USB Connection

#### 5.1.1 Installation of FTDI CDM Drivers for USB Connection

**NOTE !** You will need to have administrator rights to run the setup. If you don't have logged in with such rights, you will need to logon as such first. As an alternative, you may also run setup.exe under a different user while using right-mouse-click and select "run as..."

1. Start your control computer.
2. Switch ON the FemtoFiber® pro Control Unit at the ON/Off switch (16) at the rear panel and at the ON/OFF Key Switch (25) at the front panel.
3. Insert the Software USB flash drive to the control computer and select the folder *FemtoFiber-pro-USB-Driver\_Windows* (Figure 31).

**NOTE !** Since support of Windows XP has been terminated recently, TOPTICA no longer supports this or older operating systems. The following procedures are executed on a Windows 7 system, also including some special remarks on Windows 8. Newer operating systems have not been verified at time of issuing this manual.

**NOTE !** TOPTICA provides updated versions of drivers and GUI via [www.toptica.com](http://www.toptica.com). Please select the FemtoFiber® pro product pages. You will find latest updates in the tab "download".

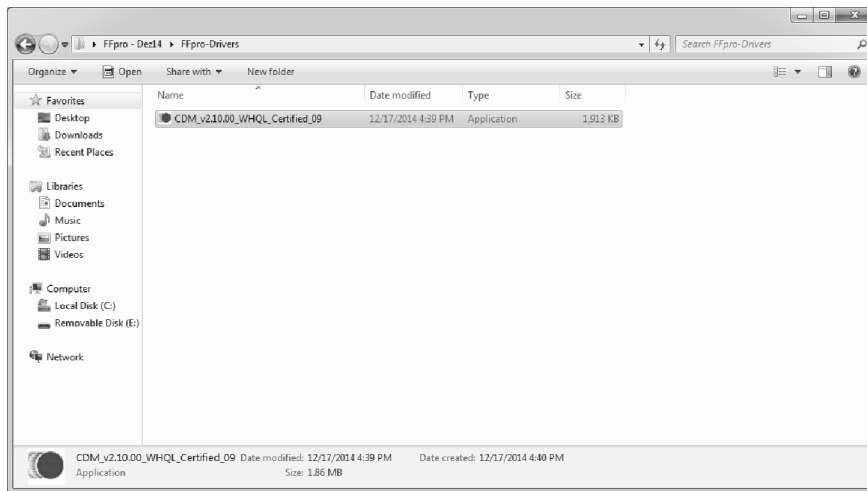

Figure 31

4. Connect the supplied USB cable first to the USB Type B connector (Figure 29: 20) of the FemtoFiber® pro Control Unit and then to the control computer.
5. Start the CDMxxx.exe installer.

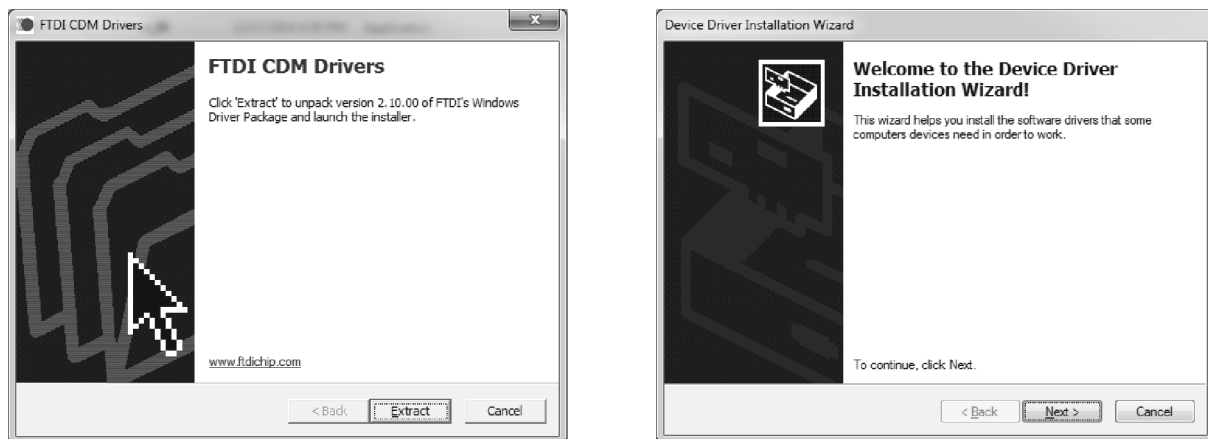

Figure 32

6. Click **Extract** to initialize the installation. The window shown in Figure 32 right appears. Click **Next** to start the installation.



Figure 33

7. Click **Finish** to complete the installation.

## 5.2 Installation of FemtoFiber® pro GUI-Software

**NOTE !** You will need to have administrator rights to run the setup. If you don't have logged in with such rights, you will need to logon as such first. As an alternative, you may also run setup.exe under a different user while using right-mouse-click and select "run as..."

1. Start your control computer.
2. Insert the Software USB flash drive to the control computer and select the folder *FemtoFiber-pro\_GUI\_Installer* and start "setup.exe".

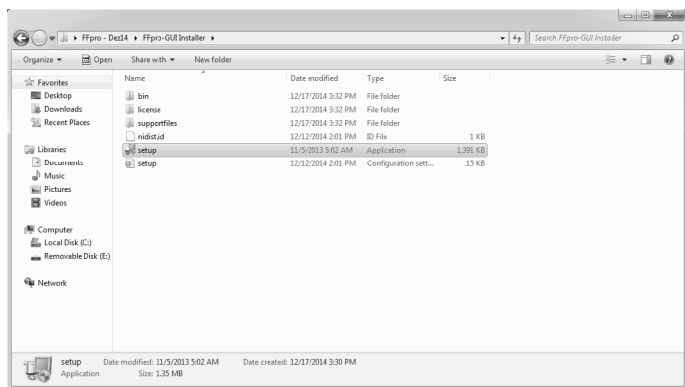

Figure 34

3. The FFpro-GUI Installation Wizard is started and prompts with the window shown in Figure 35.

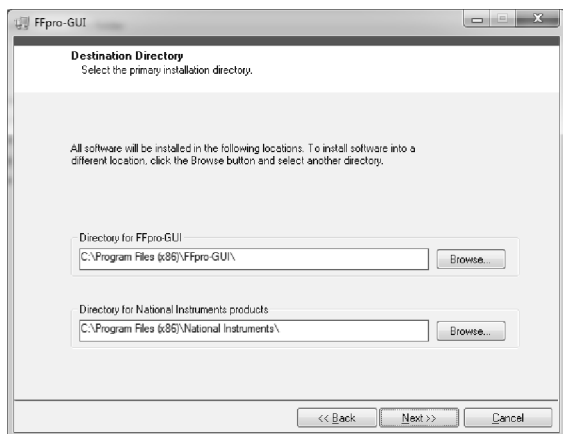

Figure 35

4. Browse to select the program folder (Default: Program Files\Ffpro-GUI\ ) and confirm with **Next**.



5. **Only Windows 8.0:**

Please check the **Disable Windows fast startup** checkbox (Figure 36) the and confirm with **Next**.

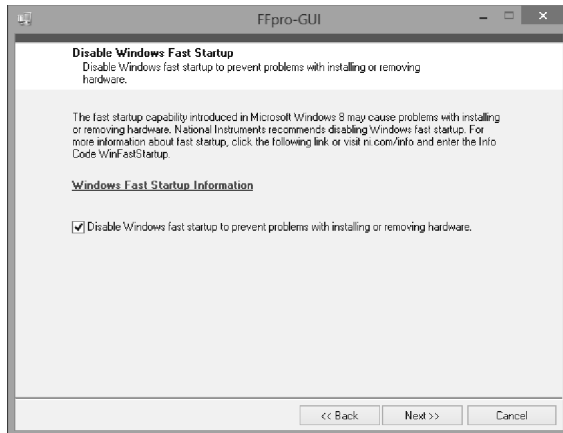

Figure 36

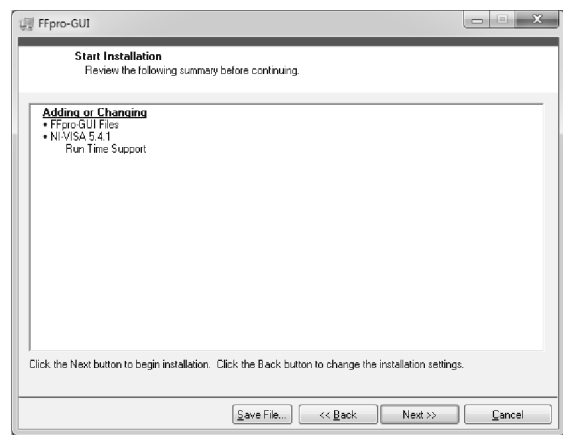
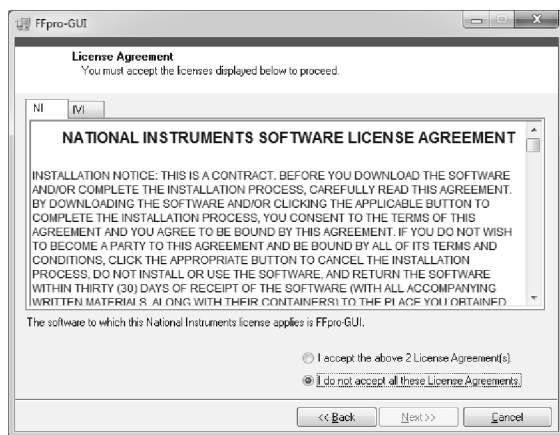

Figure 37

6. Confirm the License Agreement. Click **Next** to start the copying process (Figure 37 right).

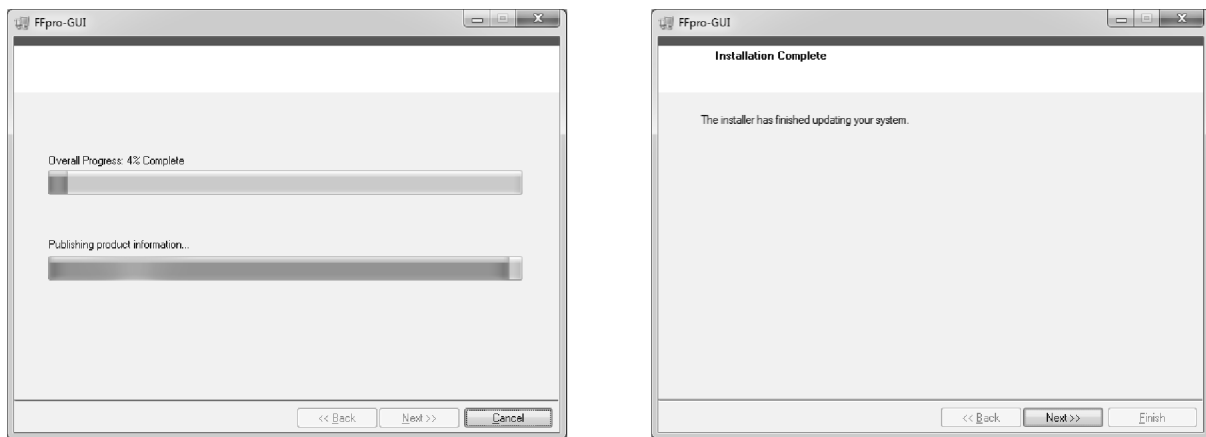

Figure 38

7. The installation progress may take several minutes. Click **Next** to exit the installation wizard (Figure 38 right).  
The window shown in Figure 39 appears.

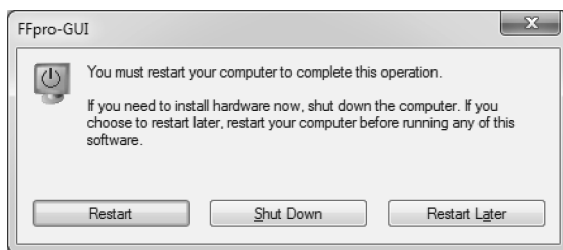

Figure 39

8. Click **Restart** to make sure that the computer is running with all the necessary drivers and libraries properly.  
When the FFpro-GUI is started for the first time, Windows firewall will interrupt with the following message (Figure 40).

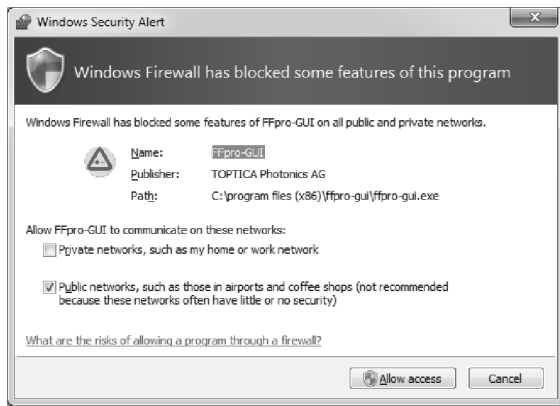
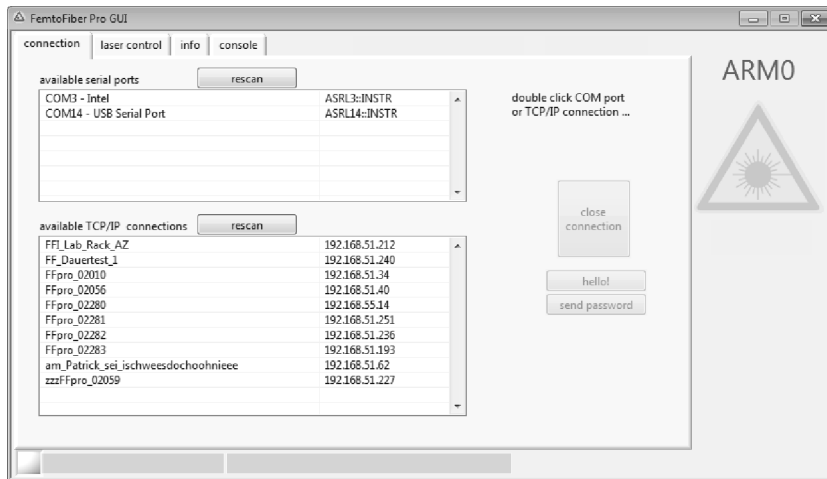

Figure 40

9. Please select the appropriate safety level and click **Allow access**.

### 5.3 Start of FemtoFiber<sup>®</sup> pro GUI-Software

The FemtoFiber<sup>®</sup> pro GUI will add a program group to your installed programs. Select "Start -> All Programs -> FFpro-GUI -> FFpro-GUI" to start the software.



**Figure 41**

After starting the FemtoFiber<sup>®</sup> pro GUI, it will automatically scan all possible connections to your FemtoFiber<sup>®</sup> pro Laser System(s). Serial and USB ports are listed in the upper boxes, laser system(s) connected via TCP/IP will be displayed in the lower box (if any).

Double-click on the desired connection to activate. If the desired port is not shown, it may be re-listed by performing a **rescan**.

**NOTE !** For **Multi-Arm Laser Systems** please make sure that the master Control Unit is connected to the control computer.

After a successful connection, the list of the available ports and systems is grey-scaled and blocked. Additionally, a green indicator at the left end of the status bar at the bottom of the screen shows that the computer is connected with the selected laser system. Next to that, the selected port and the laser head id (Serial number) is displayed.

As a last step, change to the *Laser Control* tab (see Figure 44) and use the **ON/OFF** buttons to start/stop the laser emission. When the laser emits light, a yellow colored laser warning symbol is shown at the right side of the window. For further information about the FemtoFiber<sup>®</sup> pro GUI operation please refer to section 5.4.

## 5.4 Operation of FemtoFiber® pro GUI-Software

### 5.4.1 General

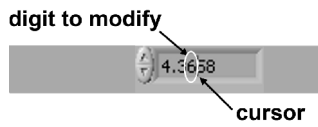

**Figure 42** Example: Changing Numeric Input Controls

#### **Changing numeric input controls:**

Set the focus on the desired numeric control (left click on the field). A cursor appears in the input field. The digit to the left of the cursor can be incremented/decremented with the up/down arrow keys. To select the desired digit use the arrow keys left/right.

## 5.4.2 Connection Tab

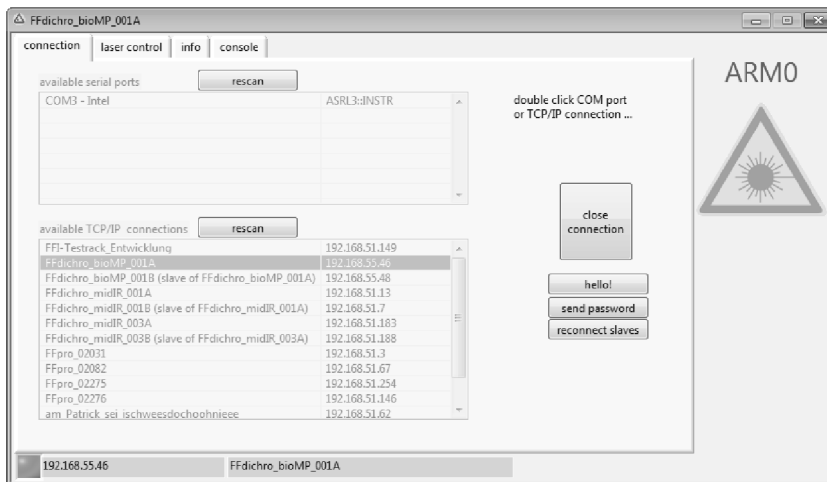

Figure 43 Connection tab

**available serial ports**

The list contains all available COM-ports of the control computer.

**rescan**

Clicking updates the corresponding list.

**available TCP/IP connections**

The list contains all available laser heads for which an Ethernet connection has been established (see section 5.5).

**close connection**

Clicking this button deactivates the current connection.

**hello!**

Clicking this button leads to an acoustic signal of the currently connected FemtoFiber® pro Control Unit.

**send password**

Only necessary for Ethernet connection: Clicking opens a window to enter a password (default: empty) to enable full control via Ethernet (userlevel 1, see section 6.8).

**reconnect slaves**

Only present with Multi-Arm systems:  
Clicking checks and updates the connection to the slave Control Units. Please use the button in case of communication malfunction to slave Control Units.

### 5.4.3 Laser Control Tab

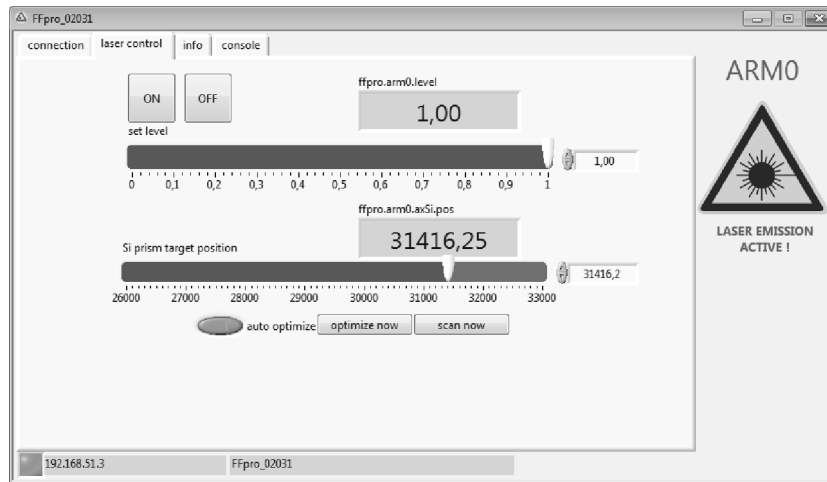

**Figure 44** Laser Control tab (example)

#### ON/OFF

Clicking switches the laser emission ON/OFF.

#### set level

Changing the **set level** reduces the laser power (1 corresponds to 100%). When the laser power is reduced, the laser is not operating under standard specification and the white Laser Radiation Emission Warning LED on the FemtoFiber® pro Laser Head is blinking.

This function is only for alignment purposes.

#### FFpro.arm0.level

Displays the actual **set level** for the main laser.

#### Si prism target position

Changing the **target position** of the motorized prism compressor allows to optimize the pulse length (IR, IRS, NIR) or spectral distribution (SCIR, UCP, TVIS, TNIR).

#### FFpro.arm0.axSi.pos

Displays the actual **target position** of the Si prism.

**NOTE !** The following operator controls are only available if the optimization feature is implemented (not available for all system variants).

#### auto optimize

Clicking switches the auto optimize feature ON/OFF. When switched ON, auto optimize constantly adjusts the average power to maximum.

**NOTE !** For constant pulse timing, auto optimize should be switched OFF !

#### optimize now

Starts the auto optimize procedure.

#### scan now

Starts a search for maximum average power over the whole prism set range and adjusts the average power to maximum.

#### Indicator laser triangle

A yellow colored laser warning symbol is shown at the right side of the window when the laser emits light.

### 5.4.4 Laser Control Tab Standard System UCP and TVIS Variant

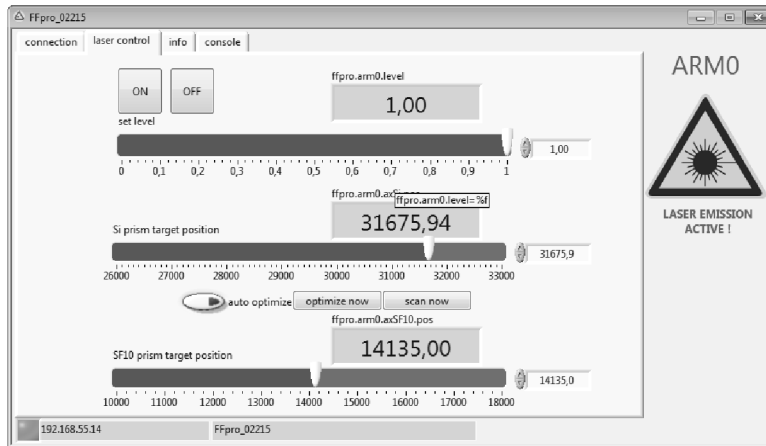

**Figure 45** Laser Control tab (example)

For description of the basic operator controls, please refer to section 5.4.3.

**NOTE !** The following operator controls are only available with the FemtoFiber® pro UCP and TVIS variant.

**SF10 prism target position**

Changing the **target position** of the motorized SF10 prism compressor allows to optimize the pulse length.

**FFpro.arm0.axSF10.pos**

Displays the actual **target position** of the SF10 prism.



### 5.4.5 Laser Control Tab Multi-Arm Laser System

With a Multi-Arm Laser System, for each arm a *Laser Control* Tab appears after the FemtoFiber® pro GUI has activated a connection to the FemtoFiber® pro main Control Unit. The number of the respective arm is displayed above the Indicator laser triangle.

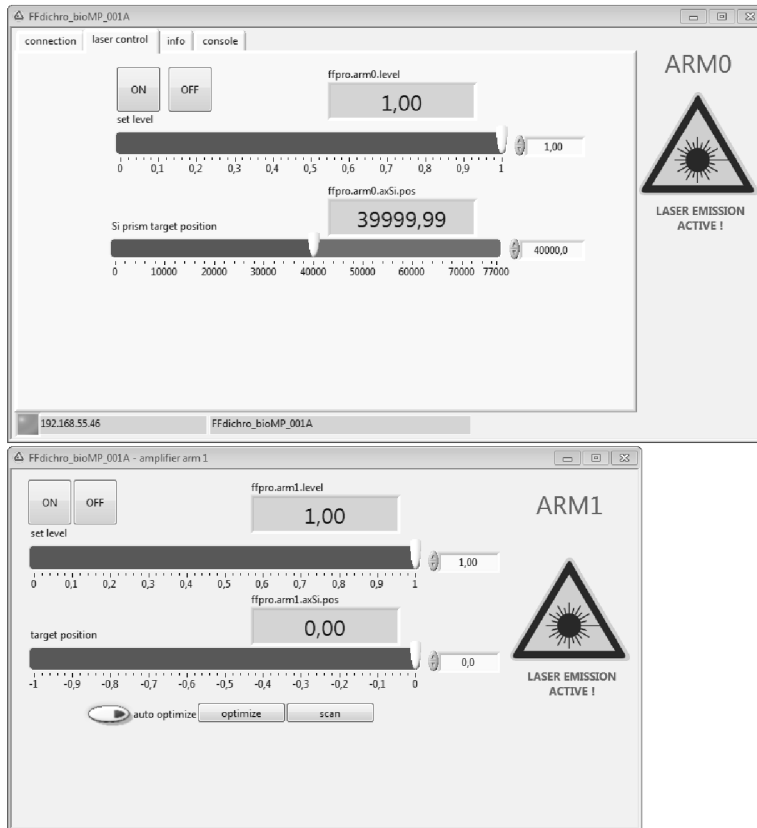

**Figure 46** Laser Control tab (example for two-arm system)

For description of the operator controls, please refer to section 5.4.3.

### 5.4.6 Info Tab

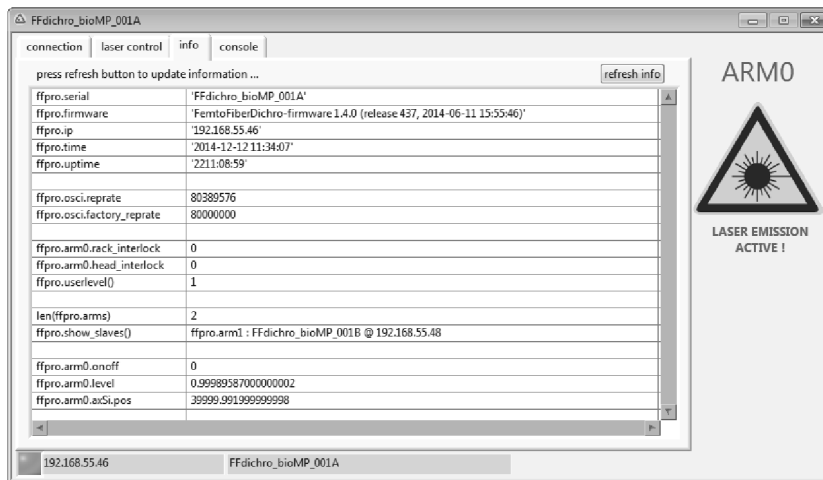

**Figure 47** Info tab

**table**

Displays FemtoFiber® pro system specific parameters.

**refresh info**

Reloads and updates the table.

### 5.4.7 Console Tab

**DANGER !** If the laser system is controlled via the Console tab, please note that the Indicator laser triangle is not updated according to the operating status of the individual laser(s). To signalize this, the Indicator laser triangle is covered with a red bar and a warning message.



**Figure 48** Console tab

**screen**

Built-in terminal to communicate with the FemtoFiber® pro laser system on the command level.

**copy all**

Copies the whole content of the terminal to the clipboard.

**copy selection**

Copies the selected content of the terminal to the clipboard.

**paste to console**

Copies the clipboard content (text only) to the terminal prompt.

## 5.5 Ethernet Connection

### 5.5.1 Installation of the Ethernet Connection

**NOTE !** To control the FemtoFiber® pro via Ethernet, first a suitable TCP/IP connection must be established.

**NOTE !** With a **Multi-Arm Laser System**, the Ethernet connection must be established for each FemtoFiber® pro Control Unit separately.

In order to set the IP address of the internal microprocessor, the FemtoFiber® pro Control Unit must be connected to the control computer by USB and the USB connection must be installed (see section 5.1). After starting the GUI software select the *Console* Tab and enter the respective command to change the IP configuration as desired:

to check the current status, type:

```
ipconfig("?") + <RETURN>
```

to set the unit as a DHCP client, type:

```
ipconfig("DHCP") + <RETURN>
```

to set a fixed IP-address, type:

```
ipconfig("xxx.xxx.xxx.xxx") + <RETURN>
```

the command is then acknowledged as follows:

```
iface eth0 inet static
    address xxx.xxx.xxx.xxx
    netmask 255.255.255.0
new configuration written
```

in order to apply the new IP address or configuration, simply enter the command

```
applyip()
```

or restart the system. After rebooting the new configuration is used.

**NOTE !** When your control computer has an active firewall installed, make sure that the Ethernet connections to the selected addresses are allowed. Otherwise, the FemtoFiber® pro GUI software is not able to detect lasers connected via Ethernet.

## 5.6 Web Frontend

**NOTE !** To control the FemtoFiber® pro via Ethernet, first a suitable TCP/IP connection must be established.

Parallel to the FemtoFiber® pro GUI Software tool, all controls are offered via a web-browser based frontend. To access the frontend, the FemtoFiber® pro Laser System must be configured for a TCP/IP Ethernet connection (please refer to section 5.5).

To communicate with the FemtoFiber® pro Control Unit simply type in the corresponding IP address:

http://xxx.xxx.xxx.xxx

where xxx.xxx.xxx.xxx represents the IP-address of the FemtoFiber® pro Control Unit.

**NOTE !** With a **Multi-Arm Laser System** only the FemtoFiber® pro main Control Unit is controlled via the operation window. All AMP systems are controlled via software commands entered in the console window.



Figure 49

By default, the selected connection is in "userlevel 0" with read-only rights. In order to access full control, the user has to login (with password if there is one installed, else simply press login). For detailed information about the userlevels, please see section 6.8.

### 5.6.1 Operation

After clicking on the "Operation" link on the web frontend homepage (Figure 49), the operation page will be displayed:

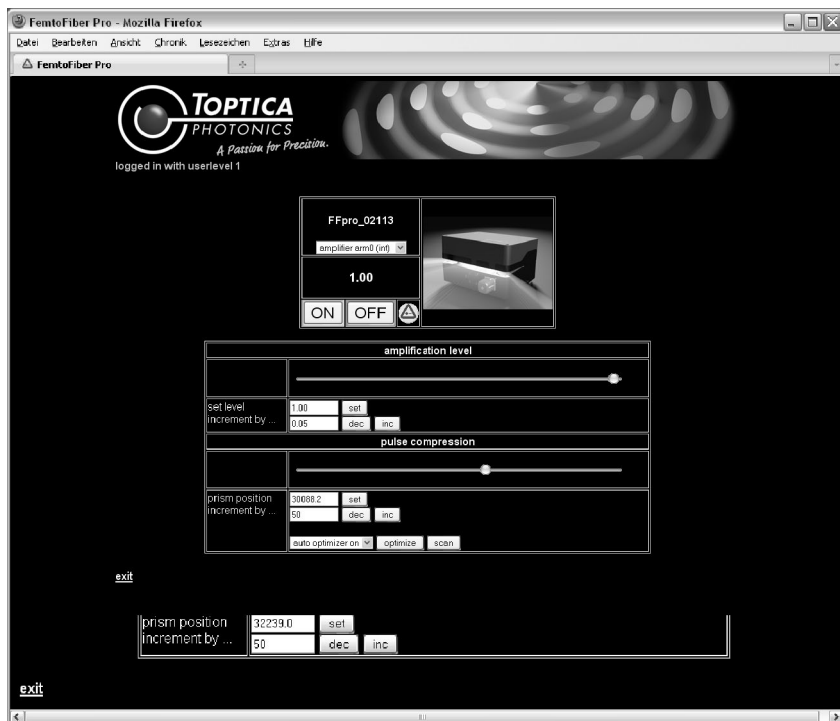

Figure 50

The control elements on this page are principally the same as on the *Laser Control* Tab of the FemtoFiber® pro GUI. For a description of the operator controls, please refer to section 5.4.3.

### 5.6.2 Python Command List

By clicking on this link, a list of the available Python commands is displayed. The commands are displayed in different colors:

**black-colored** commands are accessible by userlevel 0 and 1.

**brown colored** commands are accessible by userlevel 1 only.

For detailed information about the userlevels, please refer to section 6.8.

**NOTE !** The list of Python commands is always up-to-date. When a new firmware adds new commands, they will be also added to the list. It is therefore recommended to take the current list as a programmers reference.

**NOTE !** The command list noted in section 6.9 corresponds to firmware version 1.0.0. The current firmware version on your FemtoFiber® pro Laser System is displayed on the Python command list.

If you are not familiar with the Python script programming language, you may also read further information about the language on the command list page, by scrolling down to the end of the list. (see also section 6.7).

A very helpful Python reference is found on the internet: <http://www.python.org/doc/2.4.2/>

### 5.6.3 Console

The console window offers an integrated terminal to communicate with the FemtoFiber® pro Control Unit by typing in commands directly.



Figure 51

<b>screen</b>	Built-in terminal to display the communication with the FemtoFiber® pro laser system on the command level.
<b>command line</b>	Input field for entering software commands. The command is sent and executed by pressing ENTER.
<b>send command</b>	Sends and executes the entered command.
<b>send CTRL+C</b>	Sends a user interrupt to finish the current action.
<b>delete history</b>	Clears the screen.
<b>system summary</b>	Displays a list of system properties in the screen.
<b>selftest basic</b>	Executes basic selftest which can be performed e.g. during a measurement without disturbing the laser emission.
<b>selftest complete</b>	Executes complete selftest. This test contains the basic selftest and interrupts the laser emission. It also checks movable components e.g. prism motor position.

## 5.6.4 System Properties

This page lists a detailed report about the status of the FemtoFiber® pro Laser System. The information is more detailed than the one on the FemtoFiber® pro GUI *Info* Tab. The list is intentionally used for troubleshooting purposes.

## 5.6.5 Debug Logfile

The debug logfile lists all temporarily occurring events, from the boot-up sequence to warnings or error messages. It may be helpful for troubleshooting purposes.

<b>NOTE !</b> The list will be cleared when the FemtoFiber® pro Control Unit is switched OFF by the Key Switch at the front panel.
--

For detailed information on the messages, please see section 6.9.7.

## 5.6.6 Service Logfile

The service logfile lists all severe errors and warnings permanently. It may be helpful for troubleshooting purposes.

## 5.6.7 Data Transfer

This window shows the content of a local folder in the internal microprocessor environment. It is typically used for update processes as a temporary file drop zone. Also, when automatic measurements are performed, the measured data is stored there.

To access this folder by the control computer, simply use ftp file transfer protocol, e.g. enter

```
ftp://xxx.xxx.xxx.xxx
```

into the file browser, e.g. Windows® Explorer, where (xxx.xxx.xxx.xxx represents the FemtoFiber® pro Control Unit IP address).



### 5.6.8 Firmware Update

This page allows to upload a new firmware to the FemtoFiber® pro Control Unit. Select a file location and press upload to start the update process.

**NOTE!** With a **Multi-Arm Laser System** only the FemtoFiber® pro main Control Unit can be updated via the firmware update window. All AMP systems are updated via USB flash drive as described in section 6.5.



Figure 52

## 6 Appendix

### 6.1 Specifications of FemtoFiber® pro Laser Systems

Your laser has been manufactured to the latest specifications. For reference please see the Production and Quality Control Test Data Sheet or the TOPTICA website ([www.toptica.com](http://www.toptica.com)) for general specifications.

### 6.2 FemtoFiber® pro with VAR Option

#### 6.2.1 Installation

To install and run the laser, in general please first follow sections 3, 4 and 5 of this manual. Always follow the Safety Instructions and Warnings noted in section 2 of this manual.

The installation of the variable repetition rate control (VAR) is performed after the FemtoFiber® pro laser system has been installed. Before starting the setup for VAR, make sure that the laser is switched off. Figure 53 illustrates how the VAR accessories are connected.

#### 6.2.2 Additional Connections

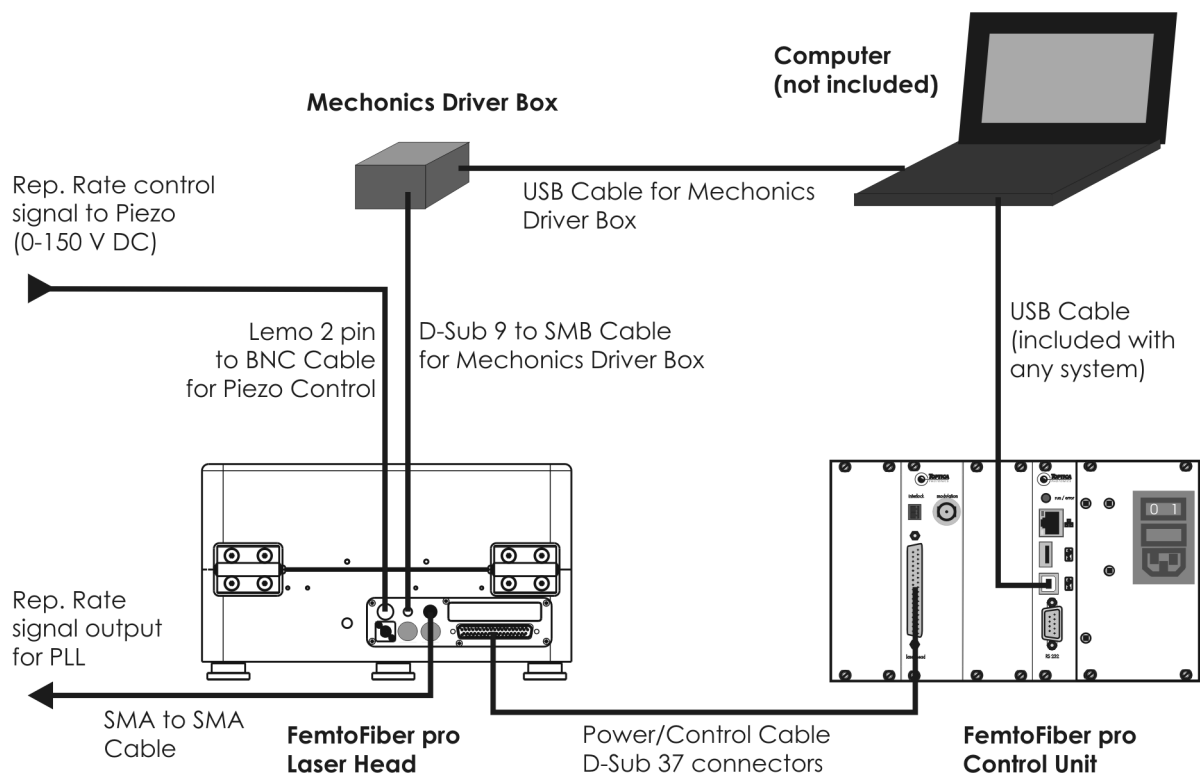

**Figure 53** Connections for FemtoFiber® pro VAR-option

For location and description of the connectors, please refer to sections 4.1 and 4.2. For the installation of the Mechanics drivers please refer to the manual included on the Mechanics CD.

## 6.3 FemtoFiber<sup>®</sup> pro with LRC Option

### 6.3.1 Installation

**NOTE !** The LRC option requires the VAR option installed in the FemtoFiber<sup>®</sup> pro laser system.

To install and run the laser, in general please first follow sections 3, 4 and 5 of this manual. Always follow the Safety Instructions and Warnings noted in section 2 of this manual.

The installation of the laser repetition rate control (LRC) is performed after the FemtoFiber<sup>®</sup> pro laser system has been installed. Before starting the setup for LRC, make sure that the laser is switched off. Figure 54 illustrates how the LRC accessories are connected.

### 6.3.2 Additional Connections

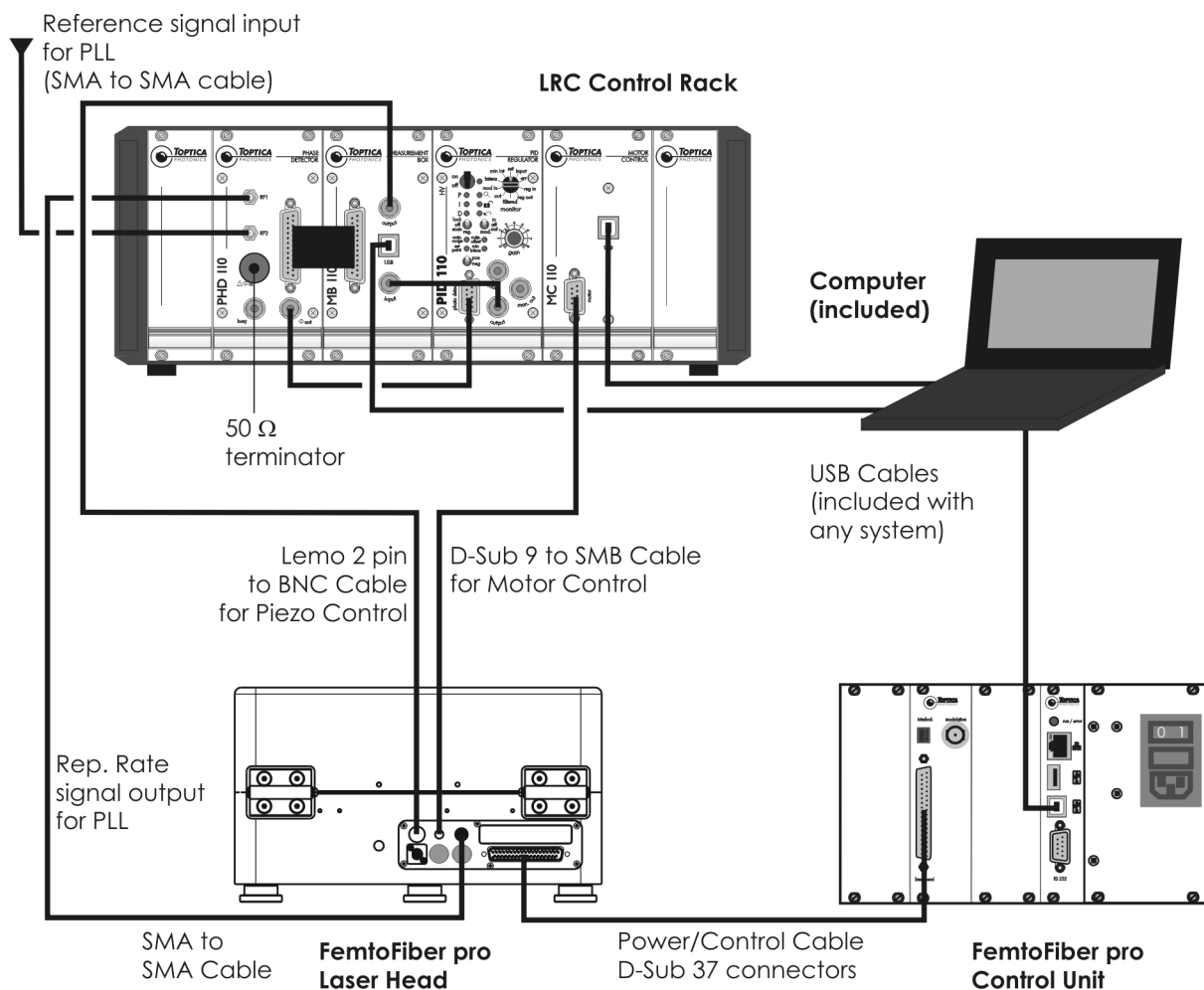

**Figure 54** Connections for FemtoFiber<sup>®</sup> pro LRC-option

For location and description of the connectors, please refer to sections 4.1, 4.2 and 6.3.3.

To set-up the required connections (see Figure 54), make sure the 12" supply rack is switched OFF at the rear side switch close to the power entry module.

**NOTE !** A description of the electronic plug in modules and their respective connections is given in section 6.3.3. Please proceed with the cabling in the same order as described there.

### 6.3.3 LRC Plug in Modules

#### 6.3.3.1 PHD 110 Module (Phase Detector)

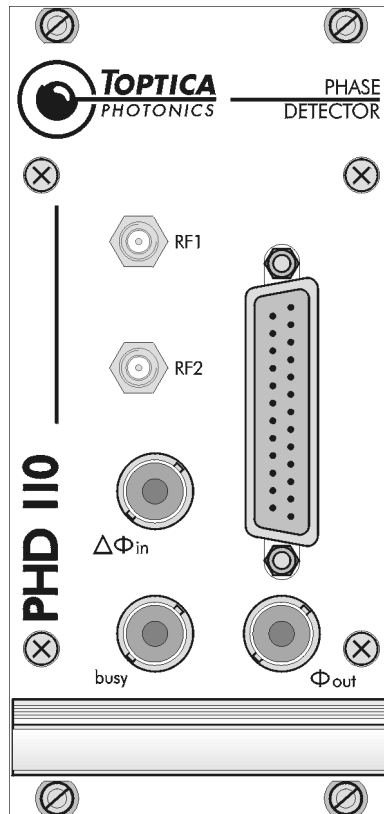

**Figure 55** Front panel of the PHD 110 module

The PHD 110 comprises an analog phase detector, which compares the instantaneous phase angles of two radio frequency signals (RF1 and RF2). The output voltage of the phase detector is proportional to the relative phase difference between the two input signals. The output is used as an error signal and fed to the PID regulator. In addition, the PHD 110 module hands over information such as the signal level of RF1 and RF2, the instantaneous phase deviation and the RMS phase jitter to the measurement unit MB 110.

#### Connections:

- Connect the first radio frequency input (RF1) to the Monitor SMA-connector at the FemtoFiber® pro laser head. Use the supplied coaxial cable with SMA/SMA connectors.
- Connect the second radio frequency input (RF2) to your existing reference oscillator.
- Using the supplied ribbon cable (D-SUB25 connectors), connect the PHD 110 module to the MB 110 module.
- Connect the Phase Output ( $\Phi_{out}$ ) BNC-connector to the Photo Detect Input of the PID 110 module. Use the supplied BNC to D-SUB9 converter cable.
- Close the Phase Difference Input ( $\Delta \Phi_{in}$ ) by the  $50 \Omega$  terminator if this input is not needed.

### 6.3.3.2 MB 110 Module (Measurement Unit)

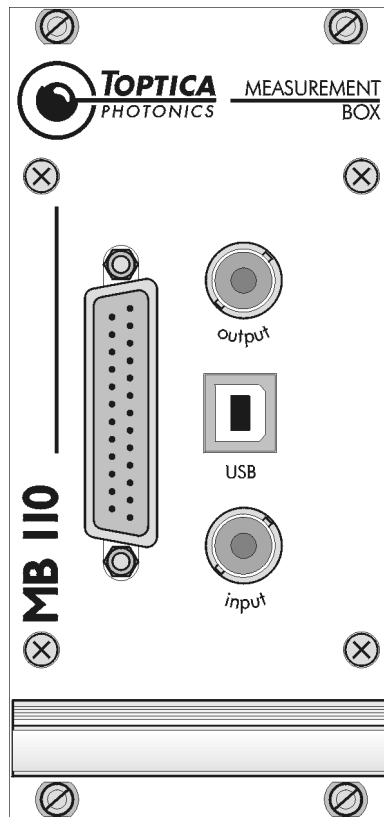

**Figure 56** Front panel of the MB 110 module

The measurement unit MB 110 contains a number of Analog-to-Digital converters which are used to process information about the operational state of the feedback loop. It obtains values for the signal level of RF1 and RF2, the instantaneous phase deviation and the RMS phase jitter from the PHD 110. In addition, it continuously samples the voltage supplied to the piezo. All this information is digitized and sent to the laptop computer via an USB connection.

#### Connections:

- Danger ! High-Voltage !**  
 Use the supplied BNC to Lemo 2 pin converter cable to connect the Output BNC-connector to the HV Piezo Lemo 2 pin-connector at the FemtoFiber® pro laser head.
- Danger ! High-Voltage !**  
 Use the BNC cable marked yellow to connect the Input BNC-connector to the Output BNC-connector at the PID 110 module.

### 6.3.3.3 PID 110 Module (PID Regulator)

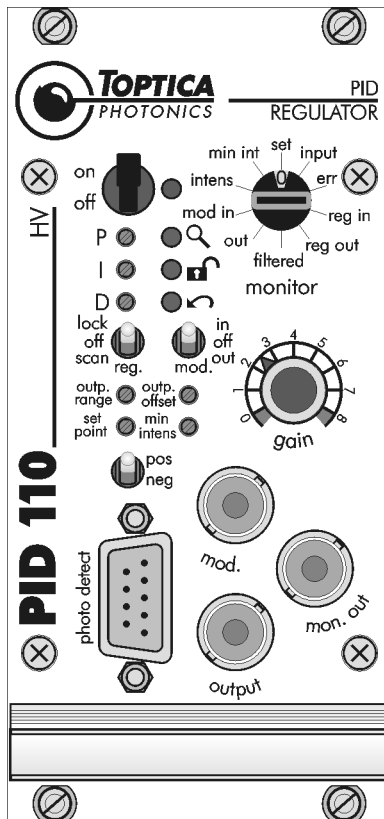

**Figure 57** Front panel of the PID 110 module

The PID 110 is a very versatile proportional integral differential regulator. In general, it is used to provide feedback to a system in a way as to minimize an error signal which has to be delivered as an input. Here the signal to be minimized is the relative phase deviation between the two radio frequency signals RF1 and RF2.

**Connections:**

- The PID 110 module has only two connections at the front panel which have already been described in the previous two sections. Therefore no further cabling is required. However, make sure that the ON/OFF switch next to the green status LED is in position OFF for now. This switch enables or disables the high voltage amplifier which drives the piezo. Check also that the "reg." switch and the "mod." switch is in position OFF. Please do not make adjustments to the settings of the P, I, and D screws and the gain control at this time, since these values have been pre-set at the company.

### 6.3.3.4 MC 110 Module (Motor Controller)

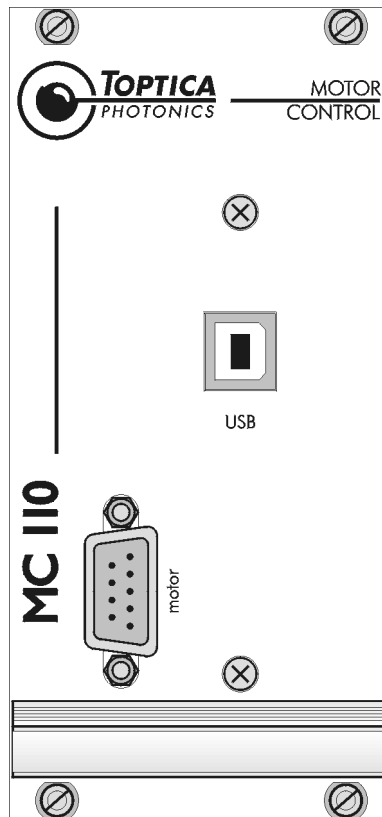

**Figure 58** Front panel of the MC 110 module

The Motor Controller MC 110 controls the motion of the linear translation stage mounted inside the FemtoFiber<sup>®</sup> pro laser head, which serves to coarsely adjust the repetition rate of the laser. Whenever the piezo voltage leaves a predefined interval around its middle value, the computer sends a trigger signal to the motor controller and the translation stage is set into motion.

#### Connections:

- Use the supplied SMB to D-SUB 9 cable to connect the Motor Stage of the FemtoFiber<sup>®</sup> pro laser head to the Motor connector at the MC 110 front panel.

### 6.3.4 LRC Software and Drivers

The provided software monitors the operating state of the feedback loop. Before the phase-locked loop can become effective, the software automatically adjusts the laser's repetition rate to the reference frequency by moving the translation stage to a proper position. As soon as the difference of RF1 and RF2 is within the capture range of the piezo, the phase-locked loop is activated.

During operation of the phase-locked loop, the software continuously monitors the piezo voltage. When the piezo voltage moves out of a certain interval, the position of the translation stage is automatically adjusted so that the piezo can return to its intended operating range.

Upon shipment, the software and the required hardware drivers are installed on the provided laptop computer. If you should decide to run the software on a different computer, please follow the software and driver installation instructions given in section 6.3.7 before proceeding further. In the following, it is assumed that you operate a computer on which the software and all hardware drivers are installed.

#### Connections:

- Start the laptop computer. Switch ON the mains switch besides the mains socket on the rear panel of the LRC control rack.

<p><b>NOTE !</b> The three USB cables have to be connected to the USB ports of the laptop computer to which they were connected at system installation. Thus the USB ports are labelled to connect the cables accordingly.</p>
--

- Use the three provided USB cables to connect your computer to the MB 110 and MC 110 modules and the FemtoFiber® pro control unit.



## 6.3.4.1 FFS Cavity Coarse Loop Software

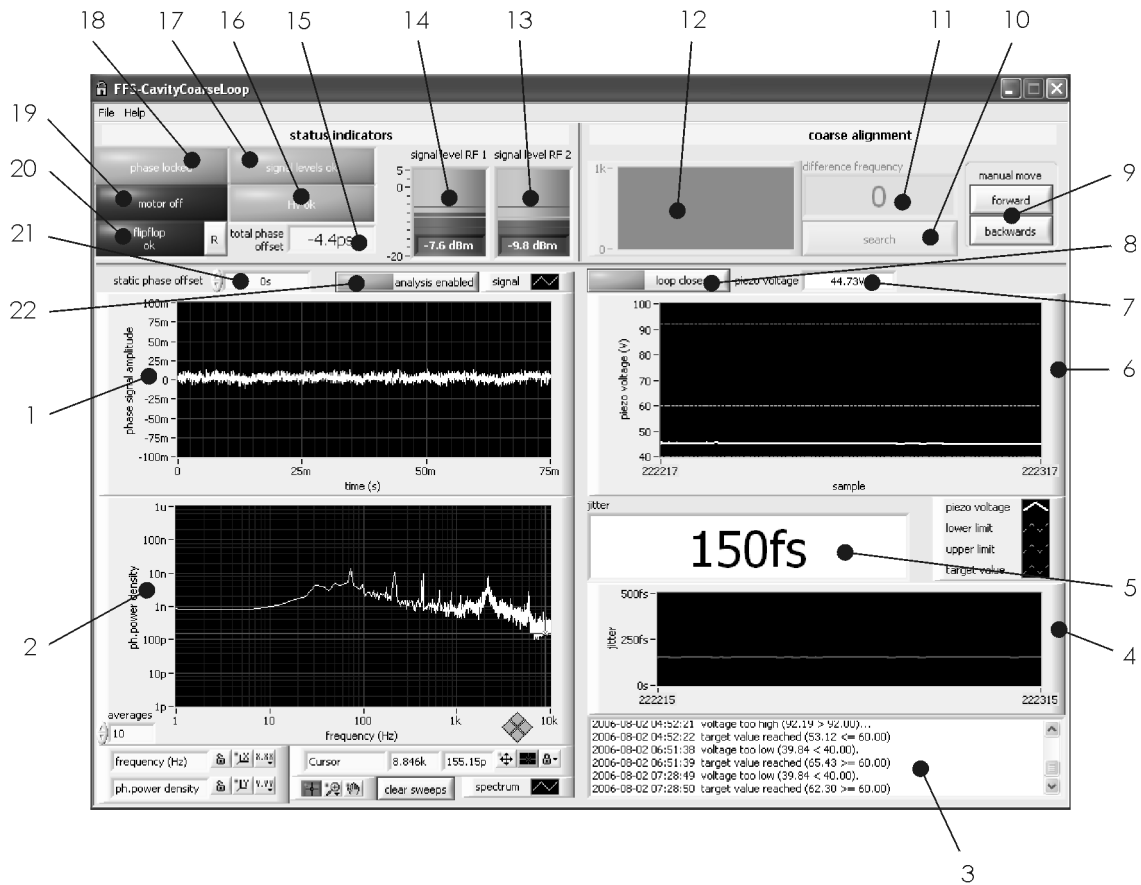
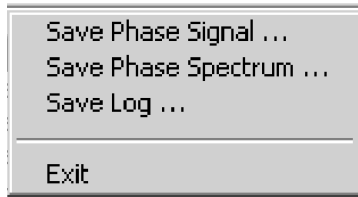

Figure 59 The FFS Cavity Coarse Loop software

1	<b>Residual Phase Difference</b> <ul style="list-style-type: none"> <li>scaling and appearance can be customized</li> <li>single plots can be exported as two column ASCII files</li> </ul>
2	<b>Spectrum of Residual Phase Difference</b> <ul style="list-style-type: none"> <li>scaling and appearance can be customized, a cursor allows convenient analysis, continuous (exponential) averaging can be applied</li> <li>single plots can be exported as two column ASCII files</li> </ul>
3	<b>Log Indicator</b> Certain events are logged in chronological order together with a timestamp Examples for events: Change of the flip-flop state, exceeding of signal level limits, start and stop of piezo motor movement etc. <ul style="list-style-type: none"> <li>the text can be exported into an ASCII file</li> </ul>
4	<b>History Plot</b> of the latest jitter values. <ul style="list-style-type: none"> <li>scaling can be customized</li> </ul>
5	<b>Jitter Indicator</b> giving the rms value of the residual phase difference as measured by a dedicated rms detector.
6	<b>History Plot</b> of the latest piezo voltages, together with the upper and lower limits and the target value.

7	<b>Piezo Voltage Indicator</b> showing the voltage applied to the piezo used to controll the phase difference.
8	<b>Coarse Loop enable/disable Button</b> When enabled, the software controls an additional slow piezo motor whenever the fast piezo has reached one of the given limits.
9	<b>Manual Move Button</b> allows to manually move the piezo motor at any time.
10	<b>Search Button</b> Pressing this button starts an automatic search alogrithm, trying to reduce the difference frequency to zero in order to enable the PID 110 regulator to lock again.
11	<b>Difference Frequency Indicator</b> whenever the PID 110 regulator falls out of lock, the data acquisition of the residual phase signal is suspended and the difference frequency between the two RF frequencies is counted. In order to enable the PID 110 to lock again it is necessary to move the piezo motor such that the frequency difference is close to zero.
12	<b>History Indicator</b> of the difference frequency.
13, 14	<b>RF Signal Level Indicator</b> giving the signal RF levels of the two inputs RF1 and RF2 in terms of dBm. In order for the phase detector to work correctly the levels have to be in the range -10 dBm to -6 dBm. The indicators turn red whenever one of the limits is exceeded, for too high signal levels additional an acoustic signal is given.
15	<b>Total Phase Offset Indicator</b> shows the total phase offset as given by the static software value plus the voltage level currently applied to the Phase in ( $\Delta\Phi_{in}$ ) BNC-connector at the PHD 110 phase detector.
16	<b>HV OK Indicator</b> indicating whether the high voltage supply for the piezo is correctly working.
17	<b>Signal Level OK Indicator</b> indicating whether the RF input levels are within the required range, turning red whenever one of the levels is out of bounds.
18	<b>Phase Locked Indicator</b> indicating whether the measured jitter value is below a given maximum value.
19	<b>Motor Busy Indicator</b> indicating whether the piezo motor is moving. Synchronously with this indicator the voltage level at the Busy BNC output of the PHD 110 phase detector is changed. The busy and the idle voltage level of the output can be user defined.
20	<b>Flip Flop Indicator</b> A fast flip-flop in the phase detector is recognizing whenever the residual phase difference exceeds a given maximum value, the flip-flop remembers such an event until it is reset by pressing the „R“ button right of the indicator. The flip-flop assures that all „out of bounds“ events are recognized by the user even if they are too fast for the software's sampling rate.
21	<b>Static Phase Offset Control</b> the phase offset between RF1 and RF2 can – within a certain range – be controlled by the software and/or the Phase in ( $\Delta\Phi_{in}$ ) BNC-connector at the PHD 110 phase detector. This control allows to enter a static (DC) phase offset of -250 ps to +250 ps (offsets are entered in units of seconds, while „1e-12“ and „1p“ are, e.g., valid entries for 1 picosecond).
22	<b>Analysis enable/disable Button</b> allows switching ON and OFF the data acquisition of the residual phase difference signal (diagrams 1 and 2), disabling the analysis improves the update rate of the other indicators as, e.g., the piezo voltage. The data acquisition is automatically disabled whenever the PID 110 regulator falls out of lock.

**Menu „File“:**

<b>Save Phase Signal</b>	saves the timeresolved residual phase signal as two-column ASCII table.
<b>Save Phase Spectrum</b>	saves the fourier transformed residual phase signal as two-column ASCII table.
<b>Save Log</b>	saves the event log text to disk.
<b>Exit</b>	exits the application

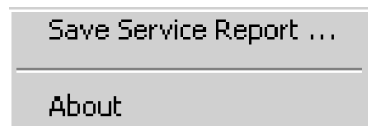
**Menu „Help“:**

<b>Save Service Report</b>	for service and support purposes; collects important information about the configuration of software and operating system in an ASCII file which can be sent to TOPTICA Photonics AG in case of problems.
<b>About</b>	opens a window showing the currently installed software version.

### 6.3.5 Quick Start

In order to use the LRC option of the FemtoFiber® pro Laser System, please proceed as follows:

1. Start the FFS Cavity Coarse Loop software on the laptop computer. On the top right corner of the program window, the difference between the laser repetition rate and the reference (11 in Figure 59) is displayed in units of Hz.
2. Switch on the PID 110 module. The piezo is now moving. Most likely, the difference between the laser repetition rate and the reference frequency is still too large to be compensated for by the piezo. Therefore the phase-locked loop is not yet working properly.
3. Press the **Search** button (10 in Figure 59) once. The software will now start to move the translation stage. If the difference frequency increases, the direction of motion will be reversed after a moment. Once the difference between the two radio frequencies RF1 and RF2 is within the capture range of the piezo, the translation stage will stop to move. From now on, the phase-locked loop is precisely controlling the repetition rate of the FemtoFiber® pro.

### 6.3.6 Switch-Off Procedure

1. Disable the control of the FFS Cavity Coarse Loop software by clicking on the **Coarse Loop enable/disable** button (8 in Figure 59) with the green indicator.
2. Close the FFS Cavity Coarse Loop software.
3. Switch OFF the PID 110 module.
4. Switch OFF the mains switch besides the mains socket on the rear panel of the LRC control rack.

### 6.3.7 Software and Driver Installation with Windows 7

**NOTE !** Due to the multitude of computers and OS versions on the market, TOPTICA is not able to guarantee the operability of the FFS Cavity Coarse Loop software on any system other than the provided computer. If you decide to run the software on a different computer or OS, you may use the following sections as a guideline for the installation. However, TOPTICA will not provide support for problems that are related to the use of equipment from third party manufacturers or OS versions not mentioned in this manual.

**NOTE !** For software and driver installation the LRC control rack must be switched on.

#### 6.3.7.1 Driver Software for Measurement Module MB 110

The analog-to-digital converter module needs to be installed and calibrated using the *InstaCal* software on the supplied TOPTICA USB flash drive.

1. Connect the MB 110 module to your computer using the supplied USB cable. A generic driver will be installed automatically by the operating system. Wait until the installation is finished.

**NOTE !** The installation of the MB 110 hardware driver is not yet completed.

2. Connect the TOPTICA USB flash drive with the *InstaCal* software to your computer. Execute the installation program *icasetup.exe*.  
The installation routine will take you through the installation process. Please follow the instructions given on the screen. After the required files have been copied to your hard disk, you are asked if you want to restart your computer now.  
Confirm with YES.
3. After the restart, open the *InstaCal* software. If *InstaCal* does not automatically detect the analog-to-digital converter in the MB 110 module, press the **Add Board** button in the *InstaCal* menu to select the converter manually. Confirm with OK. The device has now been added to the configuration file and is ready for use.
4. Exit the *InstaCal* software.

### 6.3.7.2 Driver Software for Motor Controller MC 110

The hardware driver for the MC 110 module is included on the supplied TOPTICA USB flash drive.

1. Connect the TOPTICA USB flash drive to your computer.
2. Connect the MC 110 module to your computer using the supplied USB cable. Please open the device manager and check the USB controllers of your computer for driver conflicts. Update the drivers manually if necessary.
3. Windows may inform you that the software has not passed a logo test. Confirm with "Continue Anyway". The hardware driver will now be installed.
4. After completion of the Found New Hardware Wizard, confirm with Finish.

### 6.3.7.3 FFS Cavity Coarse Loop Software

The control and monitor software for the LRC option is supplied on the TOPTICA USB flash drive which has been shipped together with your system.

1. Connect the TOPTICA USB flash drive to your computer.
2. Using the Windows Explorer, locate the program *setup.exe* on the USB flash drive.
3. Execute the setup program. The installation routine will take you through the installation process. Please follow the instructions given on the screen.
4. After restarting your computer, the program can be found on your computer under Start -> All Programs -> TOPTICA -> FFS-CavityCoarseLoop.

## 6.4 Computer Control via RS 232 Connection

1. Start your terminal programme (Windows Start/Programs/Accessories/Communication/HyperTerminal), select the COM port and set the following parameters:
  - 1.1 Enter a name for the FemtoFiber<sup>®</sup> pro Laser System terminal connection. Press OK.
  - 1.2 Select the appropriate COM port which the FemtoFiber<sup>®</sup> pro Laser System is connected to.

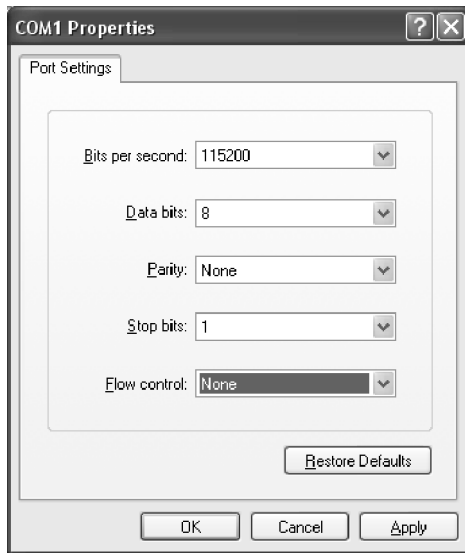

Figure 60

- 1.3 Enter the following parameters and press OK:

Baudrate:	115200	Parity:	none
Data Bits:	8	Stop Bits:	1
Flow control:	none		

2. Switch ON the FemtoFiber<sup>®</sup> pro Control Unit at the Key switch on the front panel. The HyperTerminal main window shows the boot sequence of the FemtoFiber<sup>®</sup> pro Laser System.
3. After the boot sequence is finished, commands can be entered to operate the system.

## 6.5 Firmware Update

**NOTE !** With a **Multi-Arm Laser System**, the firmware update must be performed for each individual FemtoFiber® pro Control Unit.

**NOTE !** Never switch OFF the FemtoFiber® pro Control Unit while a firmware update is performed.

When a new FemtoFiber® pro firmware is available, it can be downloaded from our website or, upon request, it is supplied on a USB flash drive for installation. The firmware is compressed in a single file which must be transferred to a USB flash drive. The USB flash drive is then plugged into the USB Type A connector (Figure 29: 19) of the FemtoFiber® pro Control Unit.

To start the update process, switch ON the Key Switch at the FemtoFiber® pro Control Unit. Start the FemtoFiber® pro GUI and select the *Console* Tab or use a web interface console.

Type in the command

```
usbupdate()
```

This will prompt you as follows:

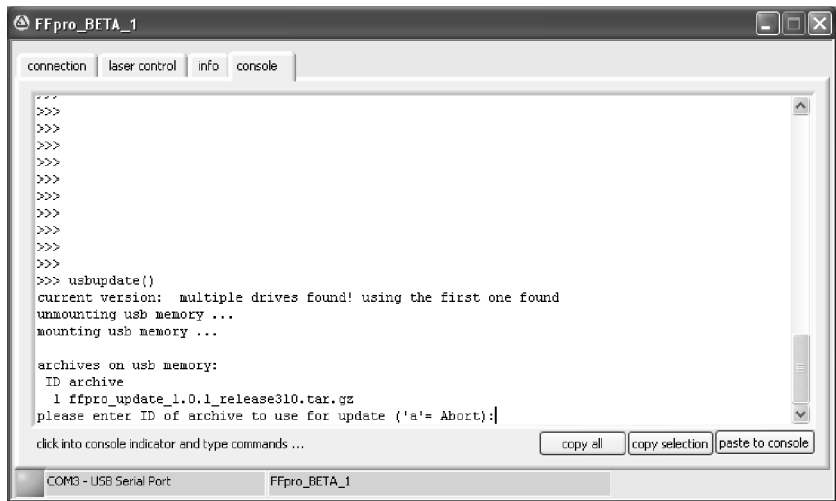
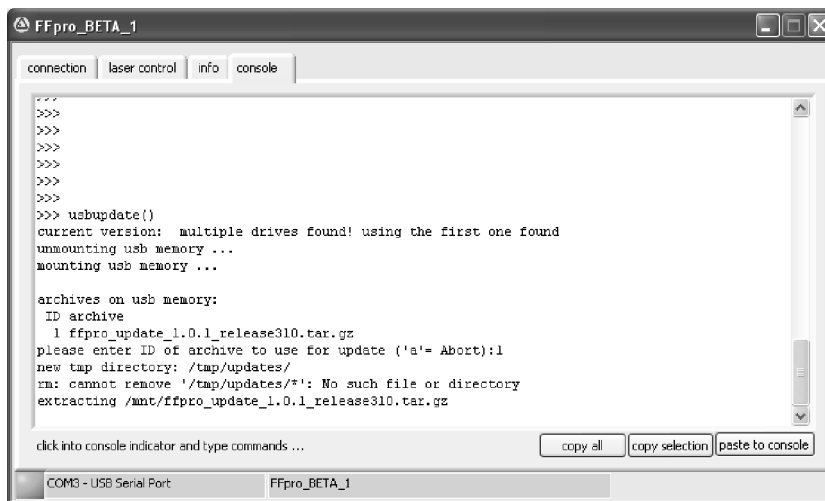

Figure 61

A list of archive files is shown. To select the correct update, type the corresponding number and press <RETURN>. The update process is started and extracts the archive file to the internal microprocessor. The procedure may take some minutes.





```

FFpro_BETA_1
connection | laser control | info | console
>>>
>>>
>>>
>>>
>>>
>>>
>>>
>>>
>>>
>>> usbupdate()
current version: multiple drives found! using the first one found
unmounting usb memory ...
mounting usb memory ...

archives on usb memory:
ID archive
  1 ffpro_update_1.0.1_release310.tar.gz
please enter ID of archive to use for update ('a'= Abort):1
new tmp directory: /tmp/updates/
rm: cannot remove '/tmp/updates/*': No such file or directory
extracting /mnt/ffpro_update_1.0.1_release310.tar.gz

click into console indicator and type commands ...
copy all | copy selection | paste to console
COM0 - USB Serial Port | FFpro_BETA_1

```

Figure 62

After finishing, the user will be informed as follows and is asked to finalize the update with a reboot of the system.

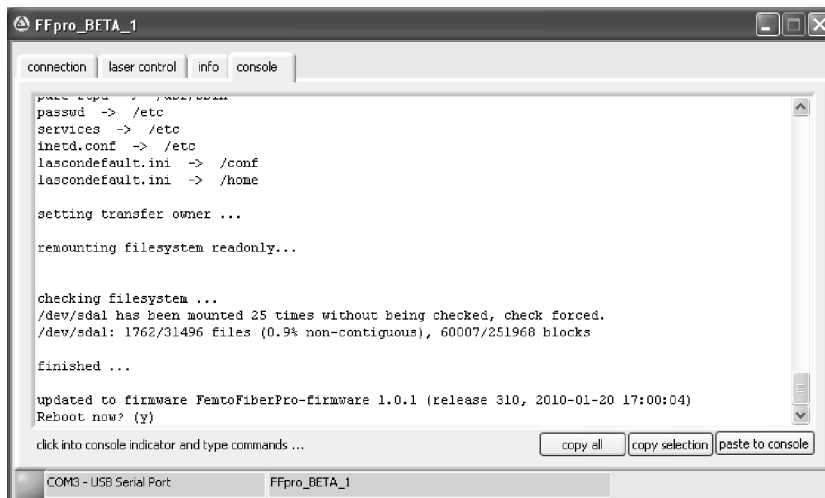

```

FFpro_BETA_1
connection | laser control | info | console
passwd -> /etc
passwd -> /etc
services -> /etc
inetd.conf -> /etc
lascondefault.ini -> /conf
lascondefault.ini -> /home

setting transfer owner ...

remounting filesystem readonly...

checking filesystem ...
/dev/sdal has been mounted 25 times without being checked, check forced.
/dev/sdal: 1762/31496 files (0.9% non-contiguous), 60007/251968 blocks

finished ...

updated to firmware FemtoFiberPro-firmware 1.0.1 (release 310, 2010-01-20 17:00:04)
Reboot now? (y)

click into console indicator and type commands ...
copy all | copy selection | paste to console
COM0 - USB Serial Port | FFpro_BETA_1

```

Figure 63

After rebooting, the system is ready to operate with the new firmware.

## 6.6 Troubleshooting

Problem	Cause	Solution
The laser does not emit light/ cannot be switched ON.	External interlock circuit closed ?	Close external interlock circuit (see section 2.5.1).
	Boot sequence finished ?	Switch ON the FemtoFiber® pro Control Unit and wait until the boot sequence is finished (see section 4.4).
The control computer can not connect to the FemtoFiber® pro Control Unit	Cable connection properly installed ?	Check cable connection.
	USB connection properly installed ?	Install USB connection as described in section 5.1.
The laser pulse length is not within the specifications.	Prism in wrong position.	Optimize prism position (see sections 5.4.3, 5.4.5 or 6.9.2).
The laser power is not within the specifications, Laser Radiation Emission Warning LED is blinking.	Set level on FemtoFiber® pro GUI <i>Laser Control</i> Tab not in Position 1.	Adjust set level to 1 (see sections 5.4.3, 5.4.5 or 6.9.4).
The red error LED lights up and a modelock-error is reported at the GUI window.	Oscillator Monitor Output is not terminated by 50 $\Omega$ .	Oscillator Monitor Output must always be terminated by 50 $\Omega$ , either by the supplied terminator plug or by the connected devices.
NIR Variant: The 780 nm laser power is not within the specifications.	Prism in wrong position.	Optimize prism position (see sections 5.4.3, 5.4.5 or 6.9.2).
NIR Variant: No 780 nm or 1560 nm laser light.	1560/780 Switch in wrong position.	Operate 1560/780 Switch as described in section 1.2.3.
SCIR Variant: Continuum not as desired.	Prism in wrong position.	Optimize prism position (see sections 5.4.3, 5.4.5 or 6.9.2).

### 6.6.1 Selftest, System Status and Error Logging

For error detection the FemtoFiber® pro Laser System is capable of performing a selftest or reporting the system status. For details please refer to sections 6.9.5, 6.9.6 and 6.9.7.

## 6.7 General Information on the Python Programming Language

The remote control language of the laser system is based on the Python programming language (Version 2.4.2). For controlling the laser, the most important elements are so-called **properties** and **commands** that are defined in addition to the standard Python language.

The laser is ready for executing the next property read-out, assignment or command after the so-called prompt ">>>" is received.

### 6.7.1 Properties

Properties are used like variables. They can be read and some of them can be assigned with new values. The property types used for controlling the laser are *integer*, *floating point* and *strings*.

Here are some examples of using properties:

Reading a string property:

```
>>> ffpro.serial
'FFPRO_2V0_0815'
>>>
```

or if you want to avoid the quotation marks:

```
>>> print ffpro.serial
FFPRO_2V0_0815
>>>
```

Integer and floating point properties can be read in a similar way:

```
>>> ffpro.reprate
39874832
>>> ffpro.arm0.level
0.75
>>>
```

Assigning new values is done in this way:

```
>>> ffpro.arm0.level=0.8
>>>
```

Combined ways of assignment are also possible:

```
>>> ffpro.arm0.level=ffpro.arm0.level / 2.0
>>> ffpro.arm0.level /= 2.0
>>>
```

## 6.7.2 Commands

In contrast to properties, commands always need brackets "( )" to be executed. Furthermore most of the commands need parameters which must be noted in the brackets. Some of the parameters might be optional and can be omitted. Commands can print out output like the commands "list()" and they can return a result value like the command "ffpro.userlevel()", and they can do both like the command "ffpro.selftest()". The difference between printed output and a result value is that a result value can be used in calculations or variable assignments etc.

Examples for executing commands:

For a command without output and without result:

```
>>> ffpro.arm0.on()
```

A command with result value can be used very similar:

```
>>> ffpro.userlevel()
0
```

But it can also be used like any other value of the respective type:

```
>>> a=ffpro.userlevel()
>>> a
0
>>> 1+ffpro.userlevel()
1
```

Commands with output but no result are used simply like this:

```
>>> systemssummary()
FFPRO_2V0_0815
=====
...
...
>>>
```

Commands with output *and* result value again can be used in different ways:

```
>>> ffpro.selftest("IO")
checking ...
...
0
>>> a=ffpro.selftest()
checking ...
...
>>> a
0
```

### 6.7.3 Error Messages

In case of a problem, an error message gives information about the source of the problem. Python error messages always consist of a so-called *traceback* and the *error type*.

Example:

```
>>> 1/0
Traceback (most recent call last):
  File "<stdin>", line 1, in <module>
ZeroDivisionError: integer division or modulo by zero
>>>
```

For remote control purposes always **the last line** of the error messages contains the most valuable information, i.e. the error type (in this case "division by zero"). The traceback in the first part of the message only describes the position of the error source in the code that was being executed. In case of our single commands it will most probably always be

```
Traceback (most recent call last):
  File "<stdin>", line 1, in <module>
```

indicating that the command, causing the error, was entered at the console (standard input, "<stdin>"). The traceback may look more complicated when scripts are executed and the error happened inside a command call, nested inside other commands. In any case the error type is noted at the end.

## 6.8 Userlevels

### 6.8.1 General

The FemtoFiber® pro can be controlled via different interfaces. While the access via RS232 and USB is limited to only one controlling PC, which is furthermore directly connected to the FemtoFiber® pro Control Unit, the access via Ethernet allows the access by multiple persons at the same time if the FemtoFiber® pro is integrated into a local area network (LAN). This possibility offers a great flexibility and, e.g. the possibility to monitor the laser performance in the office while an experiment is running in the laboratory.

However, in this case you may not want everybody in the network to be able to operate the laser, switch it ON and OFF or change any other setting. For this reason the FemtoFiber® pro control can be password protected. This protection is realized by different userlevels, i.e., different levels of control privileges:

The lowest userlevel (level 0) allows to query most of the laser settings and the laser status but does not give write access to any of the settings nor does it allow to operate anything. Userlevel 0 is not password protected.

The userlevel for regular laser operation is level 1. It offers all the commands which are necessary to operate the FemtoFiber® pro Laser System. Level 1 is password protected, but upon delivery the password is empty. When you want to connect the FemtoFiber® pro to a LAN we strongly suggest to change the password !

### 6.8.2 Changing the UserLevel

In order to simplify operation, the console access via RS232 and USB always starts with userlevel 1, meaning that the FemtoFiber® pro can immediately be controlled without the need of entering a password. This is also true for access via Ethernet as long as the level 1 password is empty (factory default).

As soon as the password is not empty, a control connection via Ethernet starts with userlevel 0, giving only limited read access. In order to control the laser, the userlevel must be changed first. The following commands are used to read the current userlevel, to change the userlevel and to change the password:

**ffpro.userlevel()** *(command, no parameter, integer result value)*

Returns the currently active userlevel.

**ffpro.changeuser()** *(command, 1 optional parameter, integer result value)*

This command allows to change the active userlevel.

After submitting the command it waits for the password input, completed by the ENTER key. Depending on the entered password the userlevel is chosen. As an option the password can be added as parameter to this function (ffpro.changeuser("mypasswd")). Unknown passwords will set userlevel 0. Result value: new userlevel

**ffpro.changepasswd()** *(command, 1 optional parameter, no result value)*

This command allows to change the password for userlevel 1. After submitting the command it waits for password input, completed by the ENTER key. The password then must be entered a 2nd time in order to avoid typos. Alternatively the new password can be added as optional parameter (ffpro.changepasswd("newpasswd").

## 6.9 FemtoFiber<sup>®</sup> pro Operation via Software Commands

### 6.9.1 Basic Operation

The FemtoFiber<sup>®</sup> pro firmware offers a very flexible and powerful language for controlling the laser with all his features. However, for basic operation a small subset of the commands is sufficient:

#### Switching ON and OFF

The fiber oscillator for seeding the amplifier stages is started already during system initialization, immediately after powering up the electronics. During normal operation there is no need to switch OFF the oscillator again, since no laser light will be emitted as long as the amplifier stages are switched OFF.

For turning ON and OFF the emission therefore the amplifiers have to be switched ON by the following commands:

**ffpro.arm0.off()** (*command, 0 parameters, no result value*)  
switch OFF emission

**ffpro.arm0.on()** (*command, 0 parameters, no result value*)  
switch ON emission

In a Multi-Arm System the additional amplifiers can be accessed in a similar way by simply replacing "arm0" with "arm1", "arm2" or "arm3", respectively.

For querying the emission status the following property can be used:

**ffpro.arm0.onoff** (*integer property*)  
on/off flag:  
\_ 1 = emission ON (oscillator and all amplifiers of arm0 are on)  
\_ 0 = no emission

### 6.9.2 Tuning the internal Pulse Compressor

Before being emitted at one of the FemtoFiber<sup>®</sup> pro apertures, the amplified pulses can be manipulated by the built-in pulse compressor in order to exhibit the phase distribution best suited for the user's needs.

The pulse compressor consists of a set of two highly dispersive prism, one of which can be moved by a motor in order to adjust the amount of dispersion applied to the pulses. The motor for the prism can easily be accessed by the user with the following commands. All positions of the prism stage are entered in  $\mu\text{m}$ , relative to a fixed position (reference position).

In order to query the current prism position use the following property:

**ffpro.arm0.axSi.pos** (*floating point property, read-only*)  
current motor position in  $\mu\text{m}$

In a Multi-Arm System the additional amplifiers can be accessed in a similar way by simply replacing "arm0" with "arm1", "arm2" or "arm3", respectively.

#### Example:

```
>>> ffpro.arm0.axSi.pos
31248.3
>>>
```

For moving the prism two different methods are possible:

**ffpro.arm0.axSi.moveabswait()** (*command, 1 parameter*)  
Move motor to absolute position and wait for arrival.  
parameter: absolute position in  $\mu\text{m}$

**Example:**

```
>>> ffpro.arm0.axSi.moveabswait(33000)
1.0
>>>
```

While the prism is moving, the laser will not accept any further commands. It is also possible to send the motor to the desired position without waiting for it's arrival:

**ffpro.arm0.axSi.target** (*floating point property*)  
motor target position in  $\mu\text{m}$

**Example:**

```
>>> ffpro.arm0.axSi.target = 33000
>>>
```

The reasonable range of motor positions can be read out by these two properties:

**ffpro.arm0.axSi.scanmax** (*floating point property*)  
stop value for optimizer scans ( $\mu\text{m}$ )

**ffpro.arm0.axSi.scanmin** (*floating point property*)  
start value for optimizer scans ( $\mu\text{m}$ )



### 6.9.3 Tuning the internal SF 10 Compressor (only UCP and TVIS)

Before being emitted at one of the FemtoFiber® pro apertures, the amplified pulses can be manipulated by the built-in SF 10 compressor in order to adjust the pulse length.

The SF 10 compressor consists of a set of two highly dispersive prism, one of which can be moved by a motor in order to adjust the amount of dispersion applied to the pulses. The motor for the prism can easily be accessed by the user with the following commands. All positions of the prism stage are entered in  $\mu\text{m}$ , relative to a fixed position (reference position).

In order to query the current prism position use the following property:

**ffpro.arm0.axSF10pos** (*floating point property, read-only*)  
current motor position in  $\mu\text{m}$

In a Multi-Arm System the additional amplifiers can be accessed in a similar way by simply replacing "arm0" with "arm1", "arm2" or "arm3", respectively.

#### Example:

```
>>> ffpro.arm0.axSF10.pos
1747.3
>>>
```

For moving the prism two different methods are possible:

**ffpro.arm0.axSF10.moveabswait()** (*command, 1 parameter*)  
Move motor to absolute position and wait for arrival.  
parameter: absolute position in  $\mu\text{m}$

#### Example:

```
>>> ffpro.arm0.axSF10.moveabswait(15000)
1.0
>>>
```

While the prism is moving, the laser will not accept any further commands. It is also possible to send the motor to the desired position without waiting for it's arrival:

**ffpro.arm0.axSF10.target** (*floating point property*)  
motor target position in  $\mu\text{m}$

#### Example:

```
>>> ffpro.arm0.axSF10.target = 1500
>>>
```

## 6.9.4 Reducing the Power Level

While the specified emission properties, such as pulse duration and output power, can only be guaranteed when the amplifier is operated with the factory set amplification level, it might be desirable to reduce the power level for alignment purposes. This can easily be done with the following property:

**ffpro.arm0.level** (*floating point property*)

level of amplification from 0.0 to 1.0 (monotonical but not linear)

In a Multi-Arm System the additional amplifiers can be accessed in a similar way by simply replacing "arm0" with "arm1", "arm2" or "arm3", respectively.

After the system boot sequence the level will be set to 1.0. This can be verified by querying its value:

```
>>> ffpro.arm0.level
1.0
>>>
```

In order to reduce the power level, simply assign a new value between 0.0 and 1.0.

```
>>> ffpro.arm0.level=0.5
>>>
```

The emitted laser power will be much lower now and the white status LED at the laser head will be blinking while the laser emission is switched ON, indicating that the pulses are not expected to fulfill the specifications now.

**NOTE !** The scale used here is monotonic, but not necessarily linear, i.e. a value of 0.5 does not mean that the emitted power is 50 % of the maximum power.

## 6.9.5 System Status

The command

**systemsummary()** (*command, no parameter, no result value*)

reports a summary of the most important system parameters, such as software and hardware versions, uptime counters etc.

This is a very useful tool for getting a survey of the system status. It provides useful information about the installed firmware, network configuration, pump laser status, motor status, recently occurred problems etc.

The command is non-invasive, i.e., it can be used during a measurement because it has no influence on the laser emission.

## 6.9.6 Troubleshooting

The FemtoFiber® pro is equipped with many sensors, helping to constantly monitor the system health and to identify problems. There are a few commands which generate debugging outputs to analyze a potential problem and to support our service staff.

### Selftest

**ffpro.selftest()** (*command, 1 optional parameter*)

Performs a automatic selftest of the laser hardware.

parameter: (optional)

\_ comma separated list of verbosity modes, and test names

Use ffpro.selftest("?") to get a list of available options on your system.

### Example:

```
>>> ffpro.selftest("basic")
```

```
....
```

```
0
```

```
>>>
```

to do a quick basic selftest, checking fundamental operation of most of the hardware components. The command will report the different steps of the selftest. In case of problems with one of the components a "FAIL" is reported together with the source of the problem. In the last line of the command output the total number of "FAILs" is reported. This basic test is non-invasive and should not disturb the current laser emission.

A more detailed selftest is done by using the command

```
>>> ffpro.selftest("complete")
```

```
....
```

```
0
```

```
>>>
```

In addition to the basic test, some more complicated and time consuming measurements are done, such as motor referencing, pump diode analysis etc. During these tests the laser emission is switched OFF and the motor is moved.

In standard mode the selftest commands only reports failures. A more detailed output is available in verbose mode, by adding a ",v" to the parameter:

```
>>> ffpro.selftest("complete,v")
```

```
....
```

```
0
```

```
>>>
```

In this mode a detailed list with all executed tests is reported. It can be a very useful source of information for our service staff in case of problems.

### 6.9.7 Error Log

For troubleshooting purposes the FemtoFiber® pro firmware maintains a log file, collecting all important events happening during operation. It contains information about the initialization process after system power up as well as a list of errors and warnings, eventually occurring later. The log file is reset upon system boot and only contains information about events that happened since laser power on time. In order to have a look at this log file use the command

**ffpro.printlog()** (*command, 1 optional parameter, no result value*)  
 Print log messages since last system boot,  
 parameter: (optional) filter type: "all","err","warn" or "alert"

**Example:**

```
>>> ffpro.printlog("all")
...
>>>
```

will print out the complete content of the log file to the console. By specifying a different filter name, the output can be reduced to only contain information of the desired priority. All log file entry have a certain priority level:

Filter	Importance	Description
err	low	"errors" are the most unimportant entries. They only report minor failures during the operation of the laser and include, e.g. mistakes such as using a command with a wrong parameter or trying to switch ON the emission without having closed the interlock circuit. Errors are supposed to have no impact on the system health.
warn	high	"warnings" produced by the FemtoFiber® pro firmware report more important events or problems. If, e.g. the FemtoFiber® pro Control Unit is switched ON without a laser head being connected, the firmware will detect this problem during initialization and report it with several warnings. Opening the interlock circuit while the emission is switched ON will switch OFF the laser emission and leave a warning in the log file.
alert	highest	"alerts" report the most severe problems. If you find some alerts on the log file, please consult the TOPTICA Photonics AG service staff.

The command ffpro.printlog() without any parameters will report only warnings and alerts. The most important entries, i.e. all warnings and alerts, are additionally collected in a persistent log file which is not deleted when the system is switched OFF. This service log file will remain until it is reset by a TOPTICA service engineer.

In order to print out it's contents use the command

**ffpro.printplog()** (*command, no parameter, no result value*)  
 Print service log messages being permanently stored in the internal flash memory.

The command does not need any parameters:

```
>>> ffpro.printplog()
...
>>>
```

The result of the commands ffpro.printlog("all") and ffpro.printplog() are also available on the lasers webpage and are also a very valuable source of information for the TOPTICA service staff in case of a problem.

### 6.9.8 Full Command Set

The commands explained above are most likely sufficient for all standard applications. If, however, more detailed information about the FemtoFiber<sup>®</sup> pro control language is needed, a PDF document with the full set of available commands is available from each laser directly. It is stored in the internal memory of the laser, is updated with each firmware update and always contains a document version compatible with the currently installed firmware.

The easiest way to get the document is downloading it from the laser's webpage. When the laser is operated without Ethernet connection the command

**usbdocu()** (*command, no parameters*)

will save a PDF document with the FemtoFiber<sup>®</sup> pro command reference to a removable storage device plugged into the Type-A USB connector at the FemtoFiber<sup>®</sup> pro Control Unit. Please make sure you have a storage device with sufficient memory plugged in. A file named "pythonlist.pdf" will be copied to the device. The device can then be removed again and the document can be viewed with any PC.

## 6.10 Declaration of CE Conformity

<b>Konformitätserklärung</b>							
Declaration of Conformity / Declaration de Conformité							
QM-Formular:	<b>F-173</b>	Stand Formular:	<b>19.03.2015</b>	Version Formular:	<b>07</b>	Seite:	<b>1 von 1</b>

Wir / We / Nous **TOPTICA Photonics AG**

Anschrift / Address / Adresse **Lochhamer Schlag 19  
82166 Graefelfing  
Germany**

erklären in alleiniger Verantwortung, daß das Produkt / *declare under our sole responsibility, that the product / déclarons sous notre seule responsabilité, que le produit*

Bezeichnung / Name / Nom **FemtoFiber pro**  
 Artikelnr. / Article No. / No. d'Article **FF PRO NIR, FF PRO IR, FF PRO IRS, FF PRO SCIR, FF PRO TNIR, FF PRO TVIS, FF PRO UCP**

Beschreibung / Description / Description **Erbium-doped Fiber lasers**

mit den grundlegenden Anforderungen der Richtlinien / *fulfills the requirements of the standard and regulations of the directives / satisfait aux exigences des normes et directives*

**2004/108/EG (Elektromagnetische Verträglichkeit), 2006/95/EG (Niederspannungsrichtlinie)**

übereinstimmt und damit den Bestimmungen entspricht. / *and therefore corresponds to the regulations of the directive. / et, ainsi, correspond au règlements de la directive.*

Angewendete harmonisierte Normen / *Applied harmonized standards: / Normes harmonisées appliquées:*

<b>DIN EN 61326-1</b>	VDE 0843-20-1:2013-07 Elektrische Mess-, Steuer-, Regel- und Laborgeräte - EMV-Anforderungen - Teil 1: Allgemeine Anforderungen (IEC 61326-1:2012); Deutsche Fassung EN 61326-1:2013 <i>Electrical equipment for measurement, control and laboratory use - EMC requirements - Part 1: General requirements (IEC 61326-1:2012); German version EN 61326-1:2013</i>
<b>DIN EN 61010-1</b>	Sicherheitsbestimmungen für elektrische Mess-, Steuer-, Regel- und Laborgeräte - Teil 1: Allgemeine Anforderungen ((IEC 61010-1:2010); Deutsche Fassung EN 61010-1:2010 <i>Safety requirements for electrical equipment for measurement, control, and laboratory use - Part 1: General requirements (IEC 61010-1:2010); German version EN 61010-1:2010</i>
<b>DIN EN 60825-1</b>	Sicherheit von Lasereinrichtungen - Teil 1: Klassifizierung von Anlagen und Anforderungen (IEC 60825-1:2007); Deutsche Fassung EN 60825-1:2007 <i>Safety of laser products - Part 1: Equipment classification and requirements (IEC 60825-1:2007); German version EN 60825-1:2007</i>

Durch nicht von uns autorisierte Änderungen am Produkt verliert diese Erklärung ihre Gültigkeit. / *Non authorized changes at the product result in the invalidity of this declaration. / Changements au produit, qui ne sont pas autorisés par nous, ont pour conséquence l'invalidité de cette déclaration.*

Gräfelfing, den 19.05.2015

Dr. Thomas Weber  
Vorstand

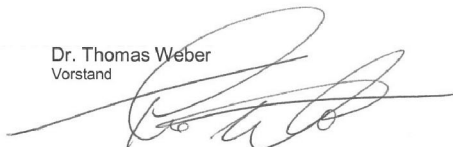

Ort und Datum der Ausstellung  
*Place and Date of Issue*  
Lieu et date d'établissement

Name und Unterschrift des Befugten  
*Name and Signature of authorized person*  
Nom et signature de la personne autorisée

## 6.11 FemtoFiber<sup>®</sup> pro Laser Head Main Dimensions (IR/IRS/NIR/SCIR)

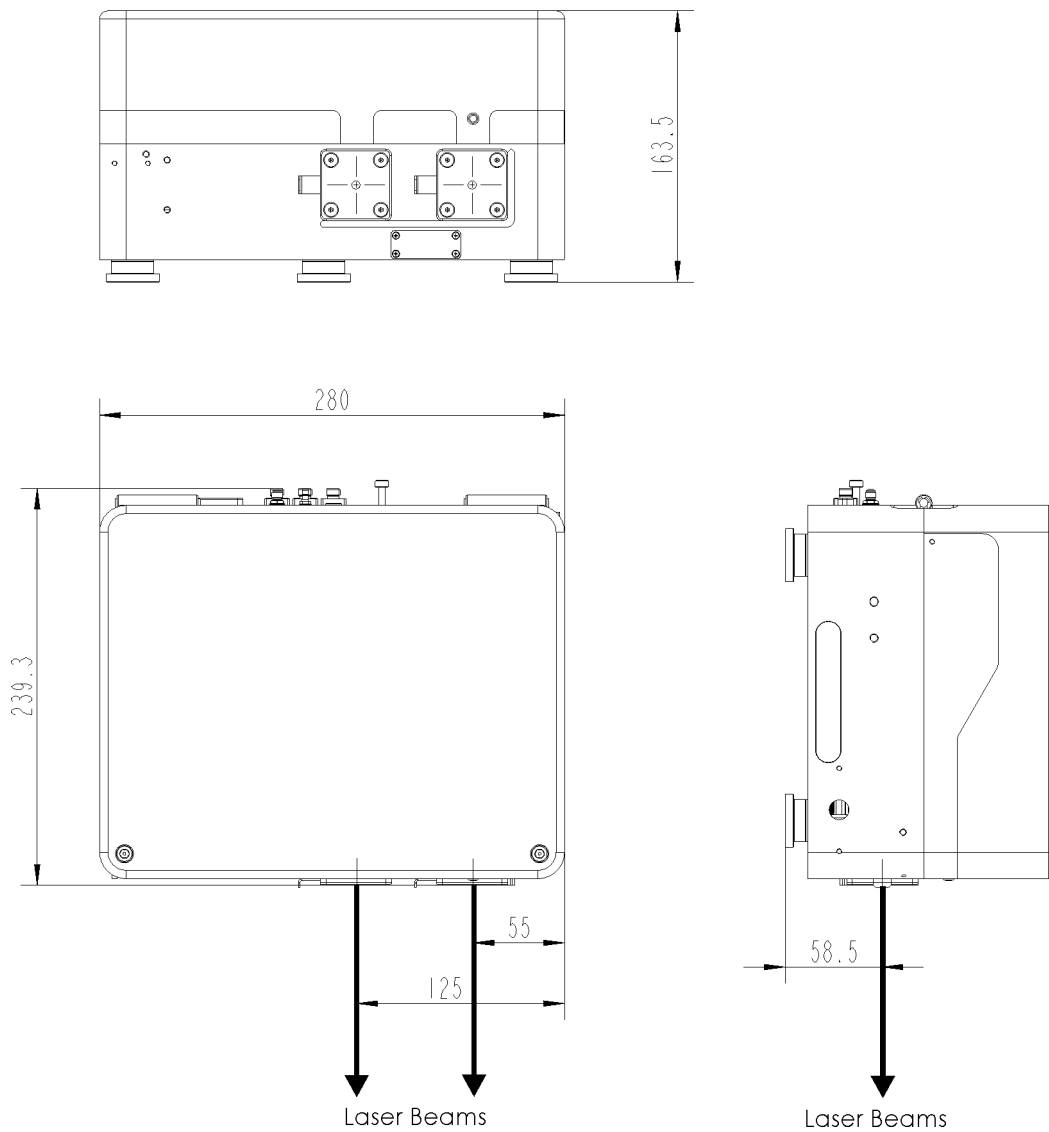

**Figure 64** FemtoFiber<sup>®</sup> pro laser head main dimensions and apertures (IR/IRS/NIR/SCIR) (all possible apertures shown)

### 6.12 FemtoFiber® pro Laser Head Main Dimensions (UCP/TNIR/TVIS)

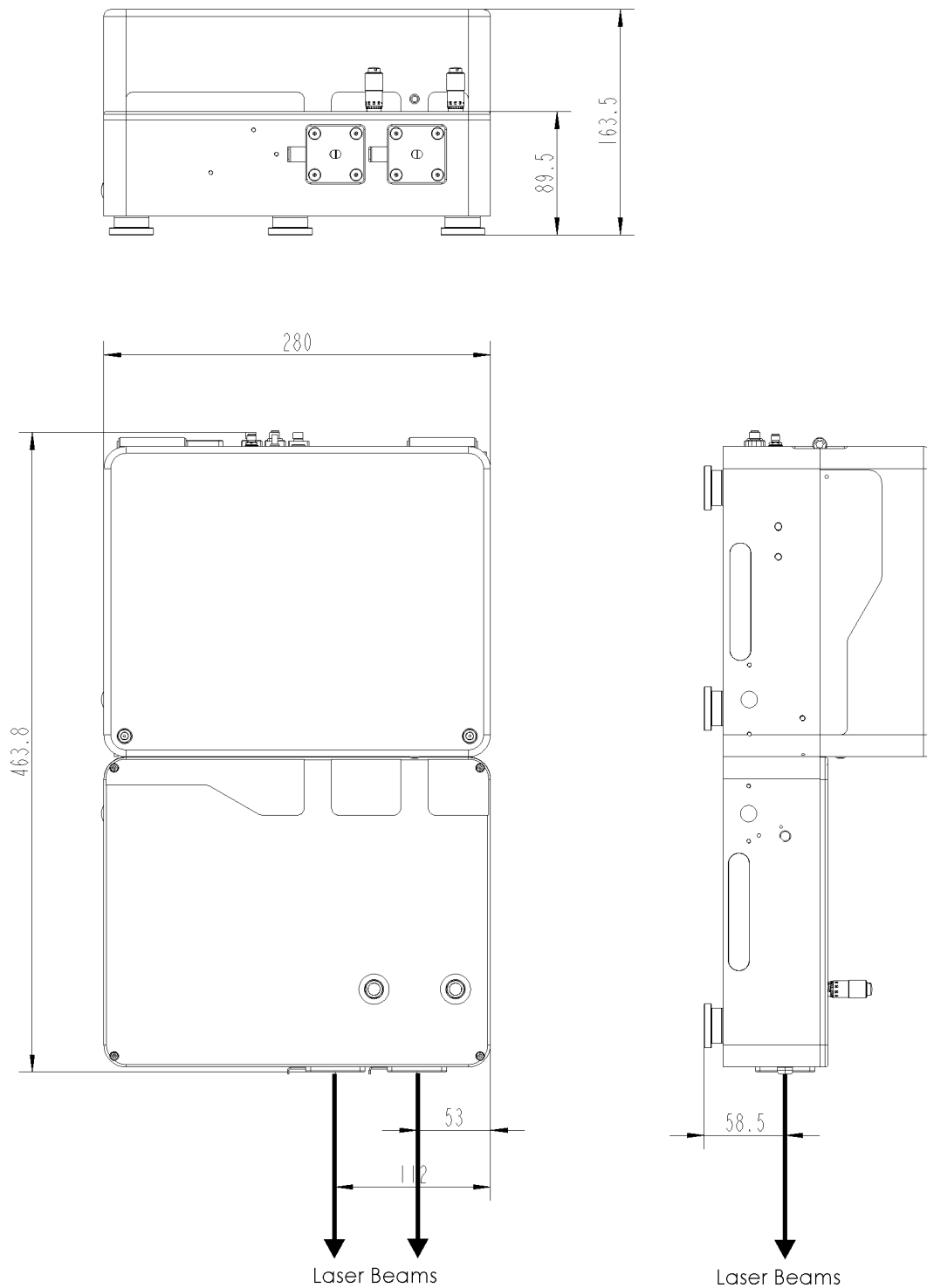

**Figure 65** FemtoFiber® pro laser head main dimensions and apertures (UCP/TVIS/TNIR) (all possible apertures shown)



### 6.13 FemtoFiber<sup>®</sup> pro Laser Head Mounting Options (IR/IRS/NIR/SCIR)

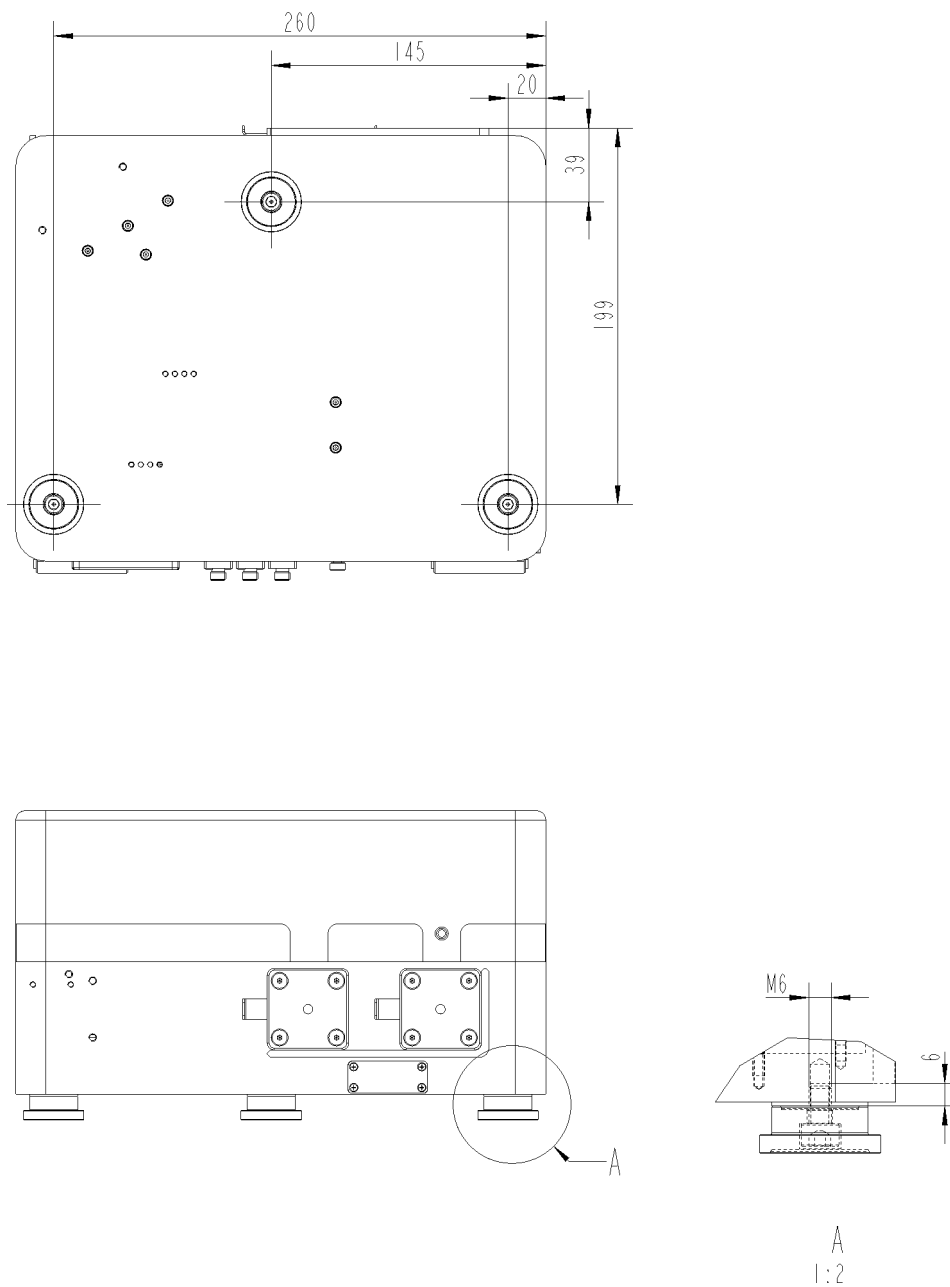

**Figure 66**

The 3 supplied posts are compatible with commercial available pedestal pillar posts, which are clamped by standard clamping forks, e.g. Newport PS-F, Thorlabs CF 125 or CF 175.

### 6.14 FemtoFiber<sup>®</sup> pro Laser Head Mounting Options (UCP/TVIS/TNIR)



**Figure 67**

The 5 supplied posts are compatible with commercial available pedestal pillar posts, which are clamped by standard clamping forks, e.g. Newport PS-F, Thorlabs CF 125 or CF 175.

## 6.15 EU Legislation for Electrical and Electronic Equipment (EEE)

Companies selling electrical and electronic goods in the European Union must conform to the EU legislation for electrical and electronic equipment (EEE), which includes the Waste Electrical and Electronic Equipment Directive (WEEE). Assigned duties affect product design of the equipment, disposal of used appliances as well as organizational responsibilities, i.e. product registration.

There are different requirements for household WEEE and that which is sold business to business (B2B). All equipment TOPTICA Photonics AG handles is classed as B2B. TOPTICA is registered at the Competent Authority (Stiftung Elektro-Altgeräte Register EAR) under No. DE70442884.

At end-of life return your product back to TOPTICA. TOPTICA will dispose used equipment in such a manner as to meet all relevant local, country and EU requirements and guideline.

To return products please mark them clearly with "intended for disposal". Contact TOPTICA prior to shipping and send them to the following address:

TOPTICA Photonics AG  
Lochhamer Schlag 19

D-82166 Graefelfing

## 7 Guarantee and Service

On the following page you will find the **Guarantee Registration Form** in which the warranty conditions are defined. Please complete in the Guarantee Registration Form immediately after you receive your device and return it to TOPTICA Photonics AG by mail or fax.

As a first step toward obtaining technical support, please contact your local distributor or visit the support pages on our web site: <http://www.toptica.com/support/>.

In case you wish to return a product for diagnosis and/or repair, please contact us prior to sending it so we can issue a **Return Material Authorization** (RMA) number for you.

You can contact us in the following ways:

- Internet: [service.toptica.com](http://service.toptica.com). In our support section you can find a list of frequently asked questions and a service contact form.
- Email: [service@toptica.com](mailto:service@toptica.com)
- Phone: +49-89-85837-150.

Our customers in the USA and Canada may contact TOPTICA Photonics Inc.:

- Phone: +1-585-657-6663

# Guarantee Registration Form



QM form: F-015	Status of form: 22.02.05	Version of form: 01	Page: 1 of 1
----------------	--------------------------	---------------------	--------------

return to

sender:

**TOPTICA Photonics AG**  
**Customer Service**  
**Lochhamer Schlag 19**  
**D- 82166 Graefelfing/Munich**  
**Germany**

---

---

---

---

---

FAX: +49 89 85837-200

## Guarantee Conditions

The products of TOPTICA Photonics AG are produced with the greatest possible care using high-quality components and are checked in detail before being delivered. Therefore, as the manufacturer, TOPTICA Photonics AG gives a guarantee of durability according to the following terms:

- TOPTICA Photonics AG guarantees the buyer that there will be no defects in the product based on defective material or processing, for a period of 12 months from first delivery (guarantee period).** Natural wear and tear as well as defects resulting from improper use or use contrary to the specifications, from failure to observe operating instructions, from insufficient maintenance and care or from modifications, interventions or attempted repairs that are neither carried out nor authorized by TOPTICA Photonics AG, are not covered by the guarantee.
- Unless expressly stated in the order acknowledgement or the invoice semiconductor light emitting devices like laser diodes, tapered amplifier chips etc. whether sold as single parts or integrated in systems are not covered by the guarantee.**
- If a defect covered by the guarantee arises during the guarantee period, TOPTICA Photonics AG shall rectify such defect within a reasonable period at its own discretion by repairing or replacing the product or the defective part.
- The guarantee period shall commence upon delivery of the product by TOPTICA Photonics AG or by a third party that obtained the product directly from TOPTICA Photonics AG for the purpose of selling it to the buyer. The claim under the guarantee shall be excluded if the defect is not notified to TOPTICA Photonics AG in writing immediately after having been discovered, and no later than one month after expiry of the guarantee period. For the purpose of rectifying a defect covered by the guarantee, the product or the relevant part shall be sent to TOPTICA Photonics AG at the expense and risk of the buyer. The product shall be returned at the expense and risk of TOPTICA Photonics AG.
- No claims may be derived from this guarantee other than claims for rectification of the defects falling within the scope hereof, in accordance with the present terms. In particular, the buyer is not entitled under this guarantee to claim damages or a reduction in price from TOPTICA Photonics AG, or to rescind the contract. Potential, more far-reaching claims of the buyer against its seller shall not be affected by this guarantee.
- Important!: The obligation of TOPTICA Photonics AG under this guarantee is subject to the condition that the buyer gives his/her express consent to them by sending the signed duplicate of this form to TOPTICA Photonics AG immediately after delivery, also truthfully indicating the model number, the serial number and the date on which the product was delivered.**
- The buyer may not assign claims under this guarantee to third parties without the prior written consent of TOPTICA Photonics AG.
- This guarantee is governed by substantive German law to the exclusion of the provisions of the UN-Convention on Contracts for the International Sale of Goods (CISG). The Regional Court [Landgericht] Munich I shall be the court of exclusive international, local and subject-matter jurisdiction for legal disputes arising under or in connection with this guarantee.

I request the above mentioned guarantee for the purchased products and herewith consent to the above mentioned Guarantee Conditions:

Model No.: \_\_\_\_\_ Date: \_\_\_\_\_

Serial No.: \_\_\_\_\_ Signature: \_\_\_\_\_

Date of Delivery: \_\_\_\_\_ Name/Title: \_\_\_\_\_

To be completed by the buyer and returned to TOPTICA Photonics AG by mail or fax (+49 - 89 - 85837 - 200).

